



Husqvarna®



## Operator's manual FS 3500 G



**English**

Please read the operator's manual carefully and make sure you understand the instructions before using the machine.

# KEY TO SYMBOLS

## Symbols on the machine:

Some of the symbols below refer to the CE market.

WARNING! The machine can be a dangerous tool if used incorrectly or carelessly, which can cause serious or fatal injury to the operator or others.



Please read the operator's manual carefully and make sure you understand the instructions before using the machine.



Wear personal protective equipment. See instructions under the "Personal protective equipment" heading.



All displacement of the machine outside the cutting area shall be carried out with the tool not in rotation.



Remove the blade prior to hoisting, loading, unloading and transporting the machine.



Arrow on tool guard indicating the direction of tool rotation.



The guards should always be fitted on the machine. Never allow blade exposure to exceed 180°.



Check the cutting attachment. Never use blunt, cracked or damaged equipment.



The blades should be marked with the same or a higher speed than that stated on the machine's rating plate. A cutting blade running at a too high speed can break or cause serious damage.



Do not use the machine near ignitable substances or gases.



WARNING! Dust forms when cutting, this can cause injuries if inhaled. Use an approved breathing mask. Avoid inhaling exhaust fumes. Always provide for good ventilation.



Hot surface.



Machinery hazard! Always keep all parts of your body away from blade and all other moving parts.



Caution, risk of cutting



Water supply adjustment



Lower blade



Switch for lower and raise the blade

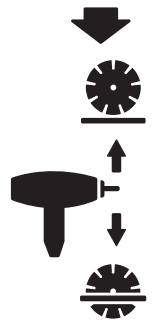

Ignition on



Engine starts



Engine stops



Machine stop



Transmission stop



Refuelling Unleaded fuel only



Choke control



Engine oil



Dipstick, maintain proper engine oil level



Do not raise the saw when checking engine oil level.



Parking brake



Activated / Deactivated



Keep saw leveled, without blade, when checking oil level.



# KEY TO SYMBOLS

Always use the machine mounted lifting eye when lifting.



This product is in accordance with applicable EC directives. If marked on the machine.



Noise emission to the environment according to the European Community's Directive. The machine's emission is specified in the Technical data chapter and on the label.



Weight



Nominal engine output, kW



Max. blade speed, rpm

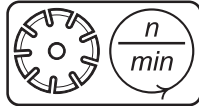

Blade diameter, mm

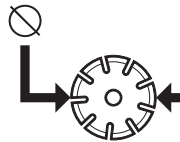

Type plate

**A:** Brand

**B:** Manufacturer, address

**C:** Type

**D, E:** Manufacturing date, year, week

**F:** Serial number

**G:** Product number

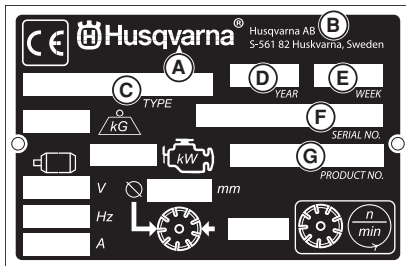

**Other symbols/decals on the machine refer to special certification requirements for certain markets.**

## Explanation of warning levels

The warnings are graded in three levels.

### WARNING!



**WARNING!** Used if there is a risk of serious injury or death for the operator or damage to the surroundings if the instructions in the manual are not followed.

### CAUTION!



**CAUTION!** Used if there is a risk of injury to the operator or damage to the surroundings if the instructions in the manual are not followed.

### NOTICE!



**NOTICE!** Used if there is a risk of damage to materials or the machine if the instructions in the manual are not followed.

# CONTENTS

## Contents

### KEY TO SYMBOLS

Symbols on the machine: .....	2
Explanation of warning levels .....	3

### CONTENTS

Contents .....	4
----------------	---

### PRESENTATION

Dear Customer, .....	5
Design and features .....	5
FS 3500 G .....	5
What is what on the floor saw - FS 3500 G .....	6
What is what on the control panel? .....	8

### MACHINE'S SAFETY EQUIPMENT

General .....	9
---------------	---

### BLADES

General .....	11
Diamond blades .....	11
Transport and storage .....	11

### FUEL HANDLING

General .....	12
Fuel .....	12
Fueling .....	12
Transport and storage .....	12

### BATTERY HANDLING

General .....	13
Connecting the battery .....	13
Disconnecting the battery .....	13
Starting the engine with a weak battery .....	13

### OPERATING

Protective equipment .....	14
General safety precautions .....	14
Service .....	14
Basic working techniques .....	15
Handle position .....	15
Moving the machine .....	16
Fitting the blade .....	17
Blade cutting depth .....	19
Straight line sawing .....	19
Hydraulic System .....	20
Transport and storage .....	20
Long-term storage .....	20

### STARTING AND STOPPING

Before starting .....	21
Starting for the first time .....	21
Starting .....	21
Stopping .....	23

### MAINTENANCE AND SERVICE

General .....	24
Measures to take in advance of maintenance, service and trouble shooting .....	24
Cleaning .....	24
Service schedule .....	25

### TROUBLESHOOTING

Incidents during sawing .....	30
-------------------------------	----

### TECHNICAL DATA

Battery .....	31
---------------	----

Hydraulic fluid and lubricants .....	31
Technical data .....	32
Noise emissions .....	34

### RELAYS AND FUSES

Relays and fuses - FS 3500 G .....	35
------------------------------------	----

### EC DECLARATION OF CONFORMITY

EC Declaration of Conformity .....	36
------------------------------------	----

# PRESENTATION

## Dear Customer,

Thank you for choosing a Husqvarna product!

It is our wish that you will be satisfied with your product and that it will be your companion for a long time. A purchase of one of our products gives you access to professional help with repairs and services. If the retailer who sells your machine is not one of our authorized dealers, ask him for the address of your nearest service workshop.

This operator's manual is a valuable document. Make sure it is always at hand at the work place. By following its content (operating, service, maintenance etc.) the life span and the second-hand value of the machine can be extended. If you will sell this machine, make sure that the buyer will get the operator's manual.

## More than 300 years of innovation

Husqvarna AB is a Swedish company based on a tradition that dates back to 1689, when the Swedish King Karl XI ordered the construction of a factory for production of muskets. At that time, the foundation was already laid for the engineering skills behind the development of some of the world's leading products in areas such as hunting weapons, bicycles, motorcycles, domestic appliances, sewing machines and outdoor products.

Husqvarna is the global leader in outdoor power products for forestry, park maintenance and lawn and garden care, as well as cutting equipment and diamond tools for the construction and stone industries.

## Owner responsibility

It is the owner's/employer's responsibility that the operator has sufficient knowledge about how to use the machine safely. Supervisors and operators must have read and understood the Operator's Manual. They must be aware of:

- The machine's safety instructions.
- The machine's range of applications and limitations.
- How the machine is to be used and maintained.

National legislation could regulate the use of this machine. Find out what legislation is applicable in the place where you work before you start using the machine.

## The manufacturer's reservation

Subsequent to publishing this manual Husqvarna may issue additional information for safe operation of this product. It is the owner's obligation to keep up with the safest methods of operation.

Husqvarna AB has a policy of continuous product development and therefore reserves the right to modify the design and appearance of products without prior notice.

For customer information and assistance, contact us at our website: [www.husqvarna.com](http://www.husqvarna.com) or call at 1-800-845-1312.

## Design and features

These walk behind floor saws are intended to use with diamond blades for wet cutting only. They are designed to cut fresh and hardened concrete in different hardness classes and asphalt.

Values such as high performance, reliability, innovative technology, advanced technical solutions and environmental considerations distinguish Husqvarna's products. Safe operation of this product requires the operator to read this manual carefully. Ask your Husqvarna dealer if you need more information.

Some of the unique features of your product are described below.

## FS 3500 G

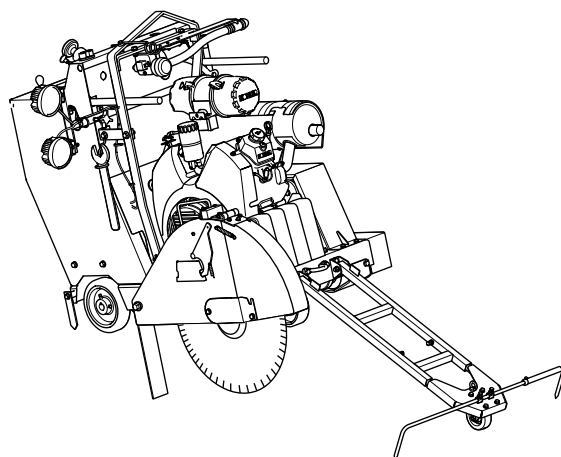

### Saw

It is robust, agile, easy to operate and maintain.

### Engine

Powerful air cooled gasoline engine with electrical start and easy to operate.

### Power transmission

Robust and efficient power transmission with dynamic belt tensioning for smooth power transfer and longer belt life.

### Front guide

Front guide has telescopic adjustment which gives good visibility and convenient storage

# PRESENTATION

## What is what on the floor saw - FS 3500 G

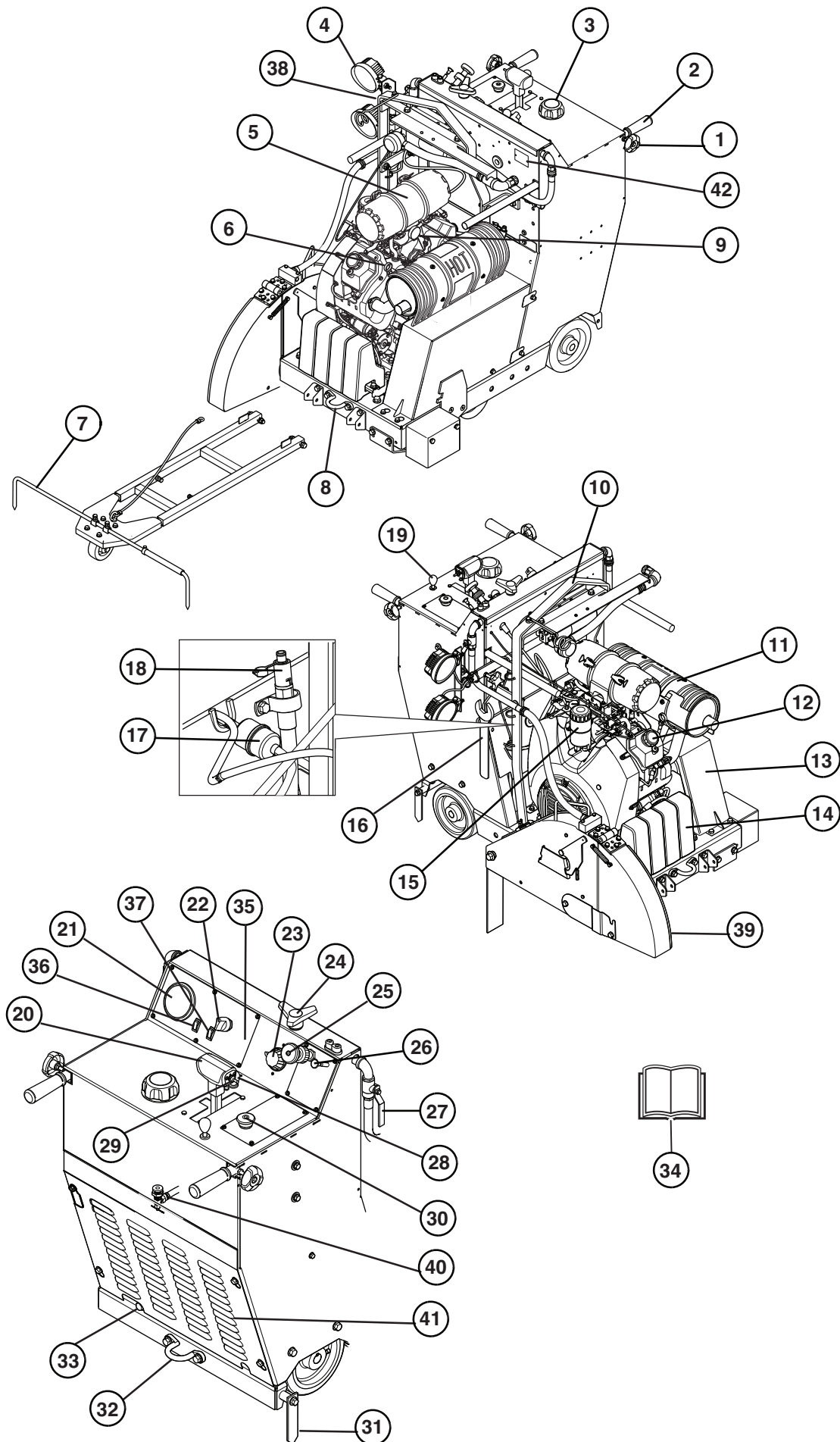

---

# PRESENTATION

---

- 1 Locking knob for handlebar adjustment
- 2 Handle bar
- 3 Fuel tank fill
- 4 Working lights
- 5 Air filter
- 6 Engine oil check (dipstick)
- 7 Front guide
- 8 Front tie-down lug
- 9 Filter minder
- 10 Lifting eye
- 11 Muffler
- 12 Engine oil fill
- 13 Drive belt cover
- 14 Weights
- 15 Engine oil filter
- 16 Blade shaft wrench
- 17 Engine fuel filter
- 18 Oil drain hose
- 19 Parking brake lever
- 20 Forward/Reverse control lever
- 21 Engine tachometer / hour meter
- 22 Engine start switch
- 23 Blade depth indicator
- 24 Blade depth stop
- 25 Engine throttle
- 26 Choke control
- 27 Water valve
- 28 Free wheel lever
- 29 Blade raise/lower switch
- 30 Machine stop
- 31 Rear pointer - right side
- 32 Rear tie-down lug
- 33 Manual axle adjustment
- 34 Operator's manual
- 35 Relay and fuse box
- 36 Water safety switch
- 37 Water pump switch
- 38 Switch for the lights
- 39 Blade guard
- 40 Fuel shut-off valve
- 41 Rear protective cover
- 42 Type plate

---

# PRESENTATION

---

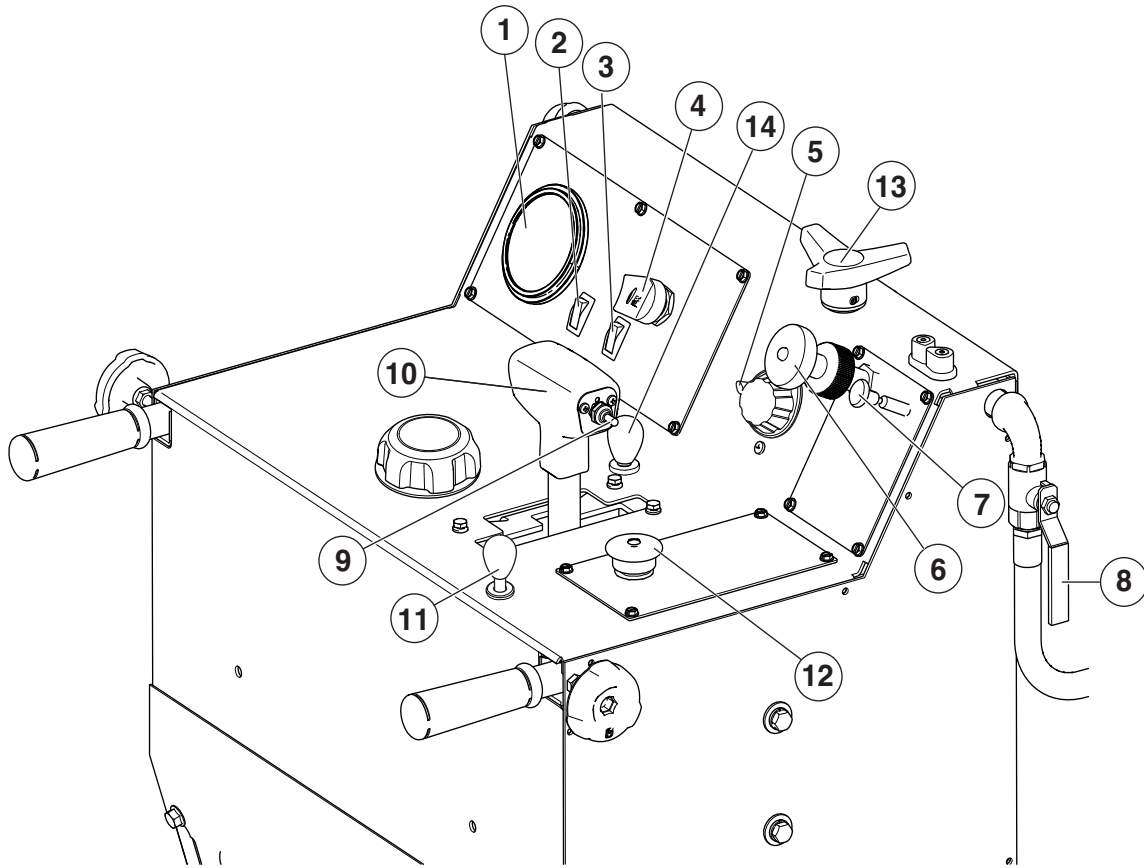

The control panel is the operator's link to the machine. From here the operator can control anything from engine rpm, cutting depth of the blade and read the current status of the engine and the machine.

## What is what on the control panel?

- 1 Engine tachometer / hour meter
- 2 Water safety switch
- 3 Water pump switch
- 4 Engine start switch
- 5 Blade depth indicator
- 6 Engine throttle
- 7 Choke control
- 8 Water valve
- 9 Raise/lower switch (blade)
- 10 Forward/Reverse control lever
- 11 Parking brake lever
- 12 Machine stop
- 13 Blade depth stop
- 14 Free wheel lever



# MACHINE'S SAFETY EQUIPMENT

## General



**WARNING!** Never use a machine that has faulty safety equipment! If your machine fails any checks contact your service agent to get it repaired. The engine should be switched off, and the Engine start switch in STOP position.



**WARNING!** The bladeshaft rotates when the engine is cranked or started.

This section describes the machine's safety equipment, its purpose, and how checks and maintenance should be carried out to ensure that it operates correctly.

## Machine stop

The machine stop is used to quickly switch off the engine and all electrical functions except lights.

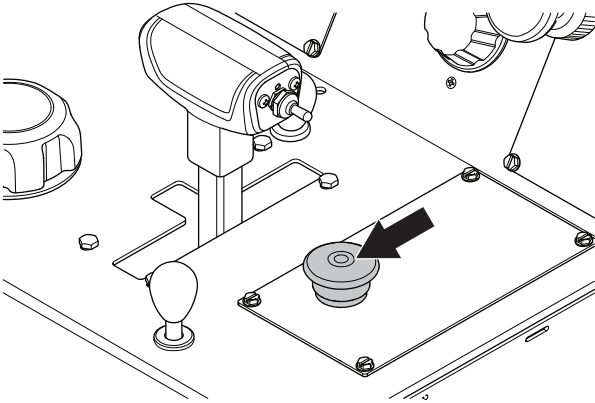

**NOTICE!** Do not use for routine stop.

## Testing the machine stop

Set the Forward/Reverse control lever to the STOP position. The engine will not start unless the lever is in the distinct STOP position.

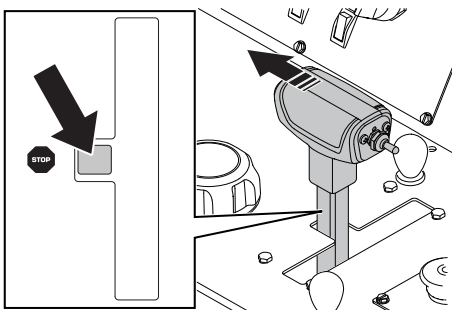

- 1 Start the engine, turn the Engine start switch to ignition on position. Follow the procedure in the engine manual.

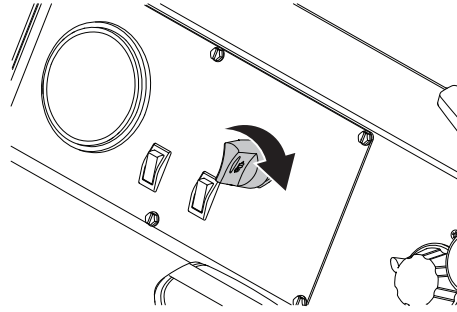

- Press the machine stop and check that the engine stops. This will set the machine in safe mode.
- Reset the machine stop by pulling the knob outward.

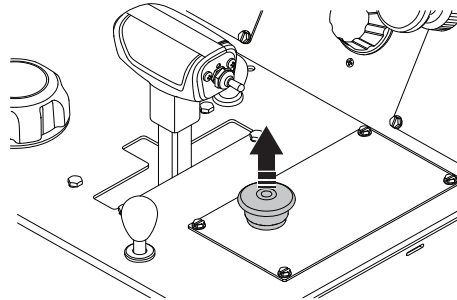

## Blade guard



**WARNING!** Always check that the blade guard is fitted correctly before starting the machine.

This guard is fitted above the blade and is designed to prevent parts of the blade or cutting fragments from being thrown towards the user.

It will also protect the user from the blade and cool the blade with water when wet cutting.

## Checking the blade guard



**WARNING!** Always check that the guard is correctly fitted before starting the machine. Also check that the blade is fitted correctly and is not damaged in any way. A damaged blade can cause personal injuries.

- Check that the blade guard is not damaged or cracked. Replace the blade guard if it is exposed to impact or is cracked.

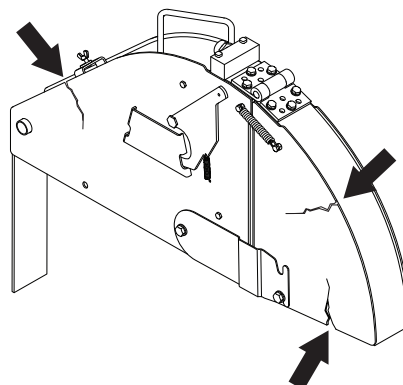

# MACHINE'S SAFETY EQUIPMENT

## Protection covers



**WARNING!** Always check that the protection covers are correctly fitted before starting the machine.

Protective covers on the machine protect the user from the cooling fan, belt drives and hot surfaces.

### Checking the protective covers

- Check the protective covers for cracks or other damages. Replace damaged covers.

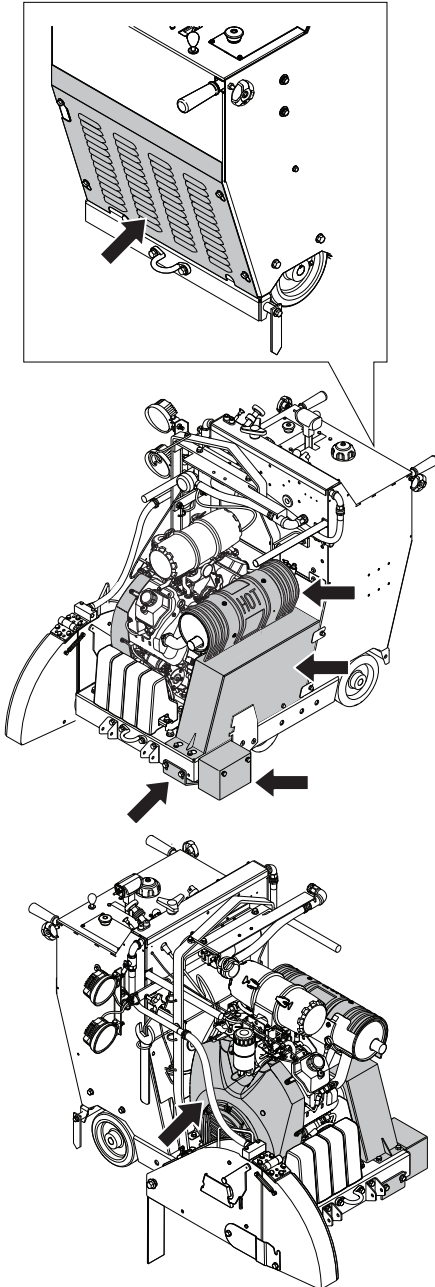

## Muffler



**WARNING!** Never use a machine without a muffler, or with a faulty muffler. A damaged muffler may substantially increase the noise level and the fire hazard. Keep fire fighting equipment handy.

The muffler gets very hot during and after use. This also applies during idling. Be aware of the fire hazard, especially when working near flammable substances and/or vapours.

The muffler is designed to keep noise levels to a minimum and to direct exhaust fumes away from the user.

### Inspecting the muffler

- Check regularly that the muffler is complete and secured correctly.

# BLADES

## General



**WARNING! A cutting blade may burst and cause injury to the operator.**

The cutting blade manufacturer issues warnings and recommendations for the use and proper care of the cutting blade. Those warnings come with the cutting blade.

**A cutting blade should be checked before it is assembled on the saw and frequently during use. Look for cracks, lost segments (diamond blades) or pieces broken off. Do not use a damaged cutting blade.**

- High-quality blades are often most economical. Lower quality blades often have inferior cutting capacity and a shorter service life, which results in a higher cost in relation to the quantity of material that is cut. See the instructions under the heading Assembling the blades.



**WARNING! Never use a blade for any other materials than that it was intended for. Never use a blade with a lower speed rating than that of the machine. Do not use circular saw blades or carbide tipped blades.**

## Blade instability

- The blade can wobble and burst if an excessive rotational speed rating is used.
- A lower rotational speed rating can stop the wobbling. Check for correct blade transmission configuration and/or gear. Otherwise replace the blade.

## Diamond blades

### General

The cutting blade continues to rotate up to a minute after the motor has stopped. Never stop the blade with your hands. Personal injuries can occur.



**WARNING! Diamond blades become very hot when used. An overheated blade is a result of improper use, and may cause deformation of the blade, resulting in damage and injuries.**

**Cutting metal generates sparks that may cause fire. Do not use the machine near ignitable substances or gases.**

- Diamond blades consist of a steel core provided with segments that contain industrial diamonds.
- Diamond blades ensure lower costs per cutting operation, fewer blade changes and a constant cutting depth.

- When using diamond blades make sure that it rotates in the direction indicated by the arrow on the blade.

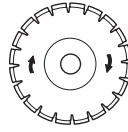

## Sharpening diamond blades

- Always use a sharp diamond blade.
- Diamond blades can become dull when the wrong feeding pressure is used or when cutting certain materials such as heavily reinforced concrete. Working with a dull diamond blade causes overheating, which can result in the diamond segments coming loose.
- Sharpen the blade by decreasing the cutting depth and engine speed for a short time. This will expose new and sharp diamonds on the blade.

## Diamond blades and cooling

- During cutting the friction in the cut causes the diamond blade to be heated up. If the blade is allowed to get too hot this can result in loss of blade tensioning or core cracking. Therefore the diamond blade needs to be cooled with water.

## Diamond blades for wet cutting

During cutting the friction in the cut causes the diamond blade to be heated up. If the blade is allowed to get too hot this can result in loss of blade tensioning or core cracking.

Allow the blade to cool down before touching it.

- Wet cutting diamond blades must be used with water to keep the blade core and segments cool during sawing. Wet cutting blades should NOT be used dry.
- Using wet cutting blades without water can cause excessive heat build-up, resulting in poor performance, severe blade damage and is a safety hazard.
- Water cools the blade and increases its service life while also reducing the formation of dust.
- Use wet sawing of old and new concrete and asphalt.

Blade size, mm/inch	Maximum cutting depth, mm/inch
500/20	193/7,75
650/26	262/10,5
750/30	312/12,5

**NOTICE! Always use blade flange size specified for current blade size. Never use damage flanges.**

## Transport and storage

- Store cutting blades in a safe place so it can not be damage.
- Store cutting blades in dry, frost free conditions.
- Inspect new blades for transport or storage damage.

# FUEL HANDLING

## General



**WARNING!** Running an engine in a confined or badly ventilated area can result in death due to asphyxiation or carbon monoxide poisoning.

Fuel and fuel fumes are highly flammable and can cause serious injury when inhaled or allowed to come in contact with the skin. For this reason observe caution when handling fuel and make sure there is adequate ventilation.

The exhaust fumes from the engine are hot and may contain sparks which can start a fire. Never start the machine indoors or near combustible material!

**Do not smoke and do not place any hot objects in the vicinity of fuel.**

## Fuel

### Petrol

- Use clean, fresh unleaded petrol.
- The lowest recommended octane grade is 90 (RON). If you run the engine on a lower octane grade than 90 so-called knocking can occur. This gives rise to a high engine temperature and increased bearing load, which can result in serious engine damage.

### Engine oil

Always park the machine on a level surface before checking the oil. Keep saw leveled, without blade, when checking oil level.

- Check the oil level before starting the machine. A too low oil level can cause serious damage to the engine. See instructions in section "Maintenance and service".
- Never use oil intended for two-stroke engines. Use only Low ash engine oil, as specified in "Technical data".

**NOTICE!** Make sure there is always sufficient oil in the engine.

## Fueling



**WARNING!** Always stop the engine and let it cool for a few minutes before refuelling.

When refuelling, open the fuel cap slowly so that any excess pressure is released gently.

Clean the area around the fuel cap.

Tighten the fuel cap carefully after refuelling. If the cap is not properly tightened the cap might vibrate lose and fuel may escape from the fuel tank creating a fire hazard.

Move the machine at least 3 m from the refuelling point before starting it.

Never start the machine:

- If you have spilled fuel or engine oil on the machine. Wipe off the spill and allow the remaining fuel to evaporate.
- If you have spilled fuel on yourself or your clothes, change your clothes. Wash any part of your body that has come in contact with fuel. Use soap and water.
- If the machine is leaking fuel. Check regularly for leaks from the fuel cap and fuel lines.

## Transport and storage

- Store and transport the machine and fuel so that there is no risk of any leakage or fumes coming into contact with sparks or open flames, for example, from electrical machinery, electric motors, electrical relays/switches or boilers.
- When storing and transporting fuel always use approved containers intended for this purpose.

# BATTERY HANDLING

## General



**WARNING! Lead-acid batteries produce explosive gases. Avoid sparks, open flames and smoking close to batteries.**

- Connecting or disconnecting the battery may cause sparks and short circuits.
- A spark or flame can cause a lead acid battery to explode.
- Never connect both terminals on the battery at the same time with a wrench or other metal as this may short-circuit the battery.
- Always handle battery with care.
- Unused batteries must be kept away from metal objects such as nails, coins, jewellery.
- Remove metal bracelets, watches, rings, etc., before connecting the battery. Wear gloves and protective goggles or a dust mask when working with the battery.
- The original battery is maintenance free. Do not attempt to open or remove caps or covers. It is usually not necessary to check or adjust the level of electrolyte.
- Replace only with a similar maintenance-free battery. See information in the Technical data section.
- When welding on the machine, always disconnect both battery cables and store cables away from battery poles.
- Always connect the minus pole of welding gear as close as possible to the weld spot.

**NOTICE!** Do not override maximum physical size of battery. Too large battery can damage or be damaged by adjacent parts.

Handle the battery carefully, of environmental considerations. Follow the local recycling requirements.

- If battery has difficulties holding voltage over long time periods when load is not applied, replace battery. For more information about recommended batteries, see section "Technical data"
- Charge battery regularly.
- Keep battery terminals and its accessories clean.

## Connecting the battery

Note! Install and remove the battery cables only in the sequence described in this section.

- 1 Install the battery holder.
- 2 Lock the battery with the pin.
- 3 Always connect positive terminal first.

- 4 Connect negative terminal.

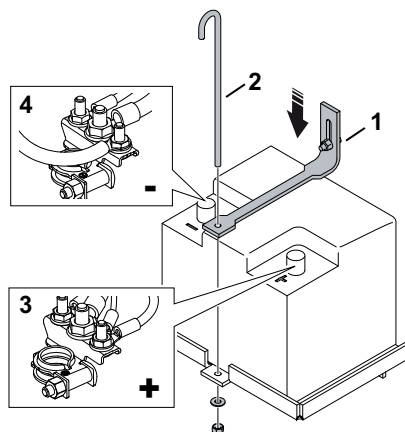

## Disconnecting the battery

- Remove the cables in the reverse order

## Starting the engine with a weak battery

If the battery is too weak to start the engine, it should be recharged.

When jump leads are used for emergency starting, follow the procedure below:

## Connecting the jump leads

- 1 Connect each end of the red cable to the POSITIVE pole (+) on each battery, exercise care not to short circuit any of the ends against the chassis.
- 2 Connect one end of the black cable to the NEGATIVE pole (-) on the fully charged battery.
- 3 Connect the other end of the black cable to a good ENGINE BLOCK EARTH, away from the fuel tank and the battery.

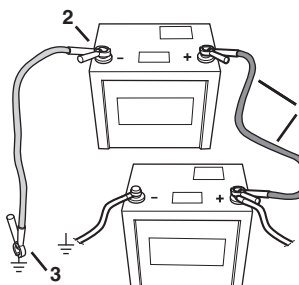

## Remove the cables in the reverse order

- The BLACK cable is removed from the engine block and then the fully charged battery.
- Finally the RED cable from both batteries.

## Storage

- Store the battery cool and dry area.

# OPERATING

## Protective equipment

### General

Make sure that there is always another person close at hand when you use the machine, so that you can call for help if an accident should occur.

### Personal protective equipment

You must use approved personal protective equipment whenever you use the machine. Personal protective equipment cannot eliminate the risk of injury but it will reduce the degree of injury if an accident does happen. Ask your dealer for help in choosing the right equipment.



**WARNING! The use of products such as cutters, grinders, drills, saws that sand or form material can generate dust and vapours which may contain hazardous chemicals. Check the nature of the material you intend to process and use an appropriate breathing mask.**

**Long-term exposure to noise can result in permanent hearing impairment. Always use approved hearing protection. Listen for warning signals or shouts when you are wearing hearing protection. Always remove your hearing protection as soon as the engine stops.**

Always wear:

- Approved protective helmet
- Hearing protection
- Approved eye protection. If you use a face shield then you must also wear approved protective goggles. Approved protective goggles must comply with standard ANSI Z87.1 in the USA or EN 166 in EU countries. Visors must comply with standard EN 1731.
- Breathing mask
- Heavy-duty, firm grip gloves.
- Tight-fitting, heavy-duty and comfortable clothing that permits full freedom of movement. Cutting generates sparks that can ignite clothing. Husqvarna recommends that you wear flame-retardant cotton or heavy denim. Do not wear clothing made of material such as nylon, polyester or rayon. If ignited such material can melt and cling to the skin. Do not wear shorts
- Boots with steel toe-caps and non-slip sole.

### Other protective equipment



**CAUTION! Sparks may appear and start a fire when you work with the machine. Always keep fire fighting equipment handy.**

- Fire Extinguisher
- Always have a first aid kit nearby.

## General safety precautions

This section describes basic safety directions for using the machine. This information is never a substitute for professional skills and experience.

- Please read the operator's manual carefully and make sure you understand the instructions before using the machine. It is recommended that first time operators also obtain practical instruction before using the machine.
- Keep in mind that it is you, the operator that is responsible for not exposing people or their property to accidents or hazards.
- The machine must be kept clean. Signs and stickers must be fully legible.

## Service

Have your machine serviced by a qualified repair person using only identical replacement parts. This will ensure that the safety of the machine is maintained.

## Always use common sense

It is not possible to cover every conceivable situation you can face. Always exercise care and use your common sense. If you get into a situation where you feel unsafe, stop and seek expert advice. Contact your dealer, service agent or an experienced user. Do not attempt any task that you feel unsure of!



**WARNING! The machine can be a dangerous tool if used incorrectly or carelessly, which can cause serious or fatal injury to the operator or others.**

**Never allow children or other persons not trained in the use of the machine to use or service it.**

**Never allow anyone else to use the machine without first ensuring that they have read and understood the contents of the operator's manual.**

**Never use the machine if you are fatigued, while under the influence of alcohol or drugs, medication or anything that could affect your vision, alertness, coordination or judgement.**

# OPERATING



**WARNING! Unauthorized modifications and/or accessories may lead to serious injury or death to the user or others. Under no circumstances may the design of the machine be modified without the permission of the manufacturer.**

**Do not modify this product or use it if it appears to have been modified by others.**

**Never use a machine that is faulty. Carry out the safety checks, maintenance and service instructions described in this manual. Some maintenance and service measures must be carried out by trained and qualified specialists. See instructions under the Maintenance heading.**

**Always use genuine accessories.**



**WARNING! This machine produces an electromagnetic field during operation. This field may under some circumstances interfere with active or passive medical implants. To reduce the risk of serious or fatal injury, we recommend persons with medical implants to consult their physician and the medical implant manufacturer before operating this machine.**

## Work area safety



**WARNING! You are responsible to ensure that animals and onlookers are not within the working area. Do not start cutting until the working area is clear.**

- Observe your surroundings to ensure that nothing can affect your control of the machine.
- Ensure that no one/nothing can come into contact with the cutting equipment or be hit by parts if the blade breaks.
- Do not install a blade on the machine until it has been transported into the cutting area.
- Do not use the machine in bad weather, such as dense fog, heavy rain, strong wind, intense cold, etc. Working in bad weather is tiring and can lead to dangerous conditions, e.g. slippery surfaces.
- Never start to work with the machine before the working area is clear and you have a firm foothold. Look out for any obstacles with unexpected movement. Ensure when cutting that no material can become loose and fall, causing injury to the operator. Take great care when working on sloping ground.
- Ensure that the working area is sufficiently illuminated to create a safe working environment.
- Make sure that no pipes or electrical cables are routed in the working area or in the material to be cut.
- Running an engine in a confined or badly ventilated area can result in death due to asphyxiation or carbon monoxide poisoning.

## Basic working techniques

- This machine is designed and intended for cutting of fresh and hardened concrete in different hardness classes and of asphalt.
- Always saw in a manner that permits easy access to the machine stop.
- Check that no tools or other objects have been left lying on the machine.
- Always check that the blade guard is fitted correctly before starting the machine. Never cut without using the blade guard.
- Clearly mark out all cuts to be made before you start sawing, plan these so they can be carried out without danger to persons or the machine.
- Under all circumstances avoid grinding using the side of the blade; it will almost certainly be damaged, break and can cause immense damage. Only use the cutting section.
- Do not stand behind or in front of the blade path while the engine is running.
- Do not leave the machine unattended while the engine is running.
- Never cock, jam wedge or twist blade in a cut.
- Make sure that there is always another person close at hand when you use the machine, so that you can call for help if an accident should occur.
- Never stand behind or in front of blade path while the engine is running. The operator position is between the two handlebars.

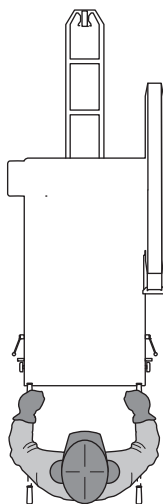

## Handle position

**CAUTION! Never use the handlebars to lift the saw.**

Use the handlebars to maneuver the saw.

The position of the handlebars can be adjusted in length.

- Loosen the locking knob **A** to adjust the length.

# OPERATING

- Set handle to most comfortable working length. Tighten the locking knob.

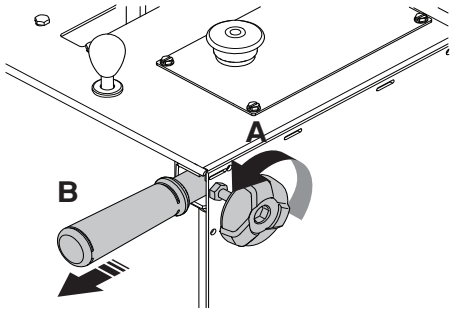

## Moving the machine

Prior to moving the machine, read and understand section "Starting and stopping".

## Moving the machine with the engine off

- Turn Engine start switch to "RUN" position.

Raise the saw by pressing up the Raise/lower switch on the Forward/Reverse control lever until the blade (if installed) clears the pavement surface.

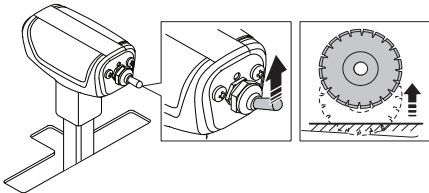
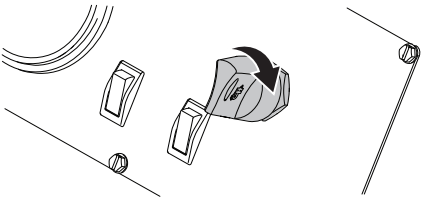

- Put Forward/Reverse control lever into the Stop/Neutral position.

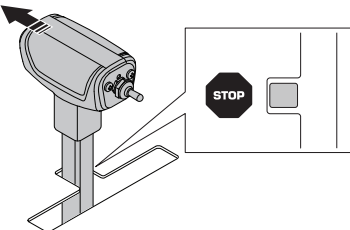

- Pull freewheel lever on control panel to its highest position.

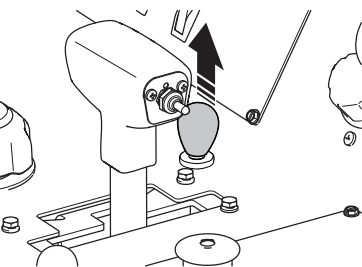

- The saw can now be moved by standing behind it and pushing (while holding the handlebars).



**WARNING!** Do not attempt to push the saw while it is in neutral position on a grade (or hill). The saw operator could lose control of the saw and cause injury to oneself or other persons in the area.

## Moving the saw with the engine on

- Raise the saw by pressing up the Raise/lower switch on the Forward/Reverse control lever until the blade (if installed) clears the pavement surface.

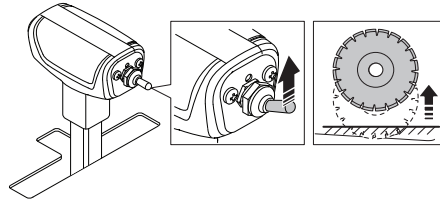

**WARNING!** Never transport the machine outside the cutting area with engine on and with a blade installed.

- Set the Water safety switch to the OFF position.

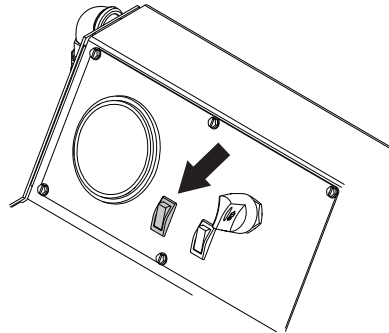

- Put the Forward/Reverse control lever into the Stop/Neutral position. The engine will not start unless the lever is in the Stop/Neutral position.

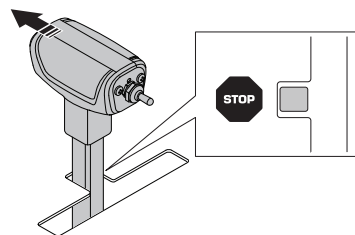

- Pull out the Engine Choke (A).

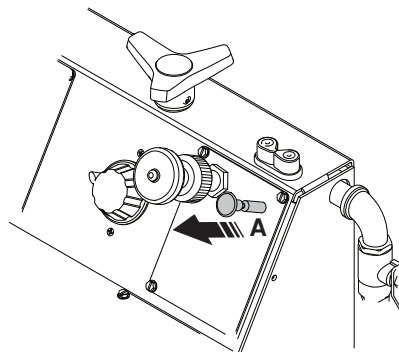



# OPERATING

- Turn the Engine start switch to the engines start position until the engine starts, then release the switch. It will return to ignition on position automatically. If the engine does not start, repeat these steps.

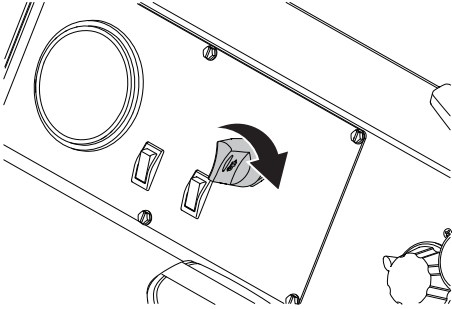

- Push the Forward/Reverse control lever forward for forward saw movement, or to the rear for reverse saw movement.

The further you push the lever the faster the speed. For more information, see the "Technical data" section.

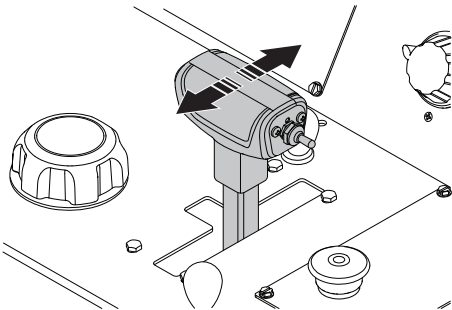

**WARNING! Do not put transmission in neutral while the machine is parked on a grade or hill. The operator will lose control and injury or damage could occur.**

Adjust the resistance on the Forward/Reverse control lever with the nut on the side of the lever.

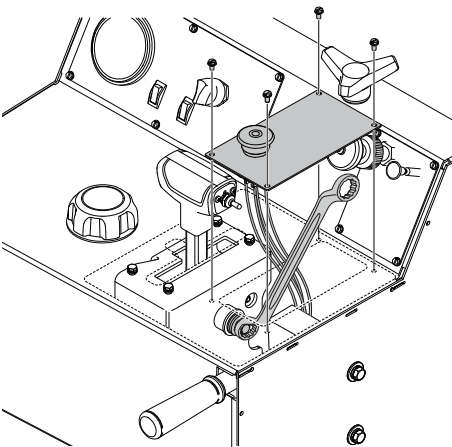

## Fitting the blade



**WARNING! Always set the engine start switch to the OFF position before installing the blade.**

**NOTICE! Check the blade's direction of rotation. The arrow on the blade and the blade guard indicates the direction of rotation.**

- 1 Transport the machine to within the cutting area and check your surroundings according to the information found under the heading Cutting area safety.
- 2 Set Engine start switch to ignition on position.
- 3 Raise the saw to a high position using the Raise/lower switch on the Forward/Reverse control lever.
- 4 Set the engine start switch to OFF position.
- 5 Press the Machine stop on the control panel.
- 6 Turn off the Water valve.

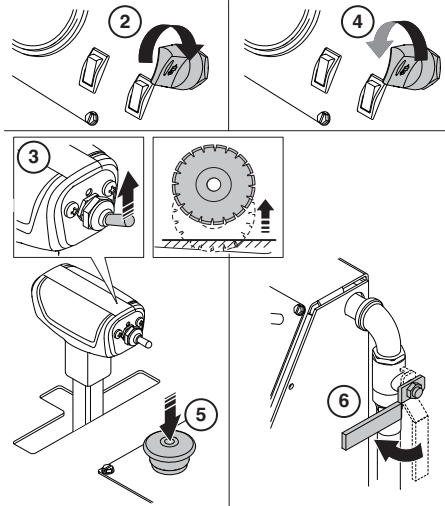

- Loosen the blade guard front bolt and lift the blade guard latch.
- Raise blade guard front and use quick release pin to lock it in upright position.

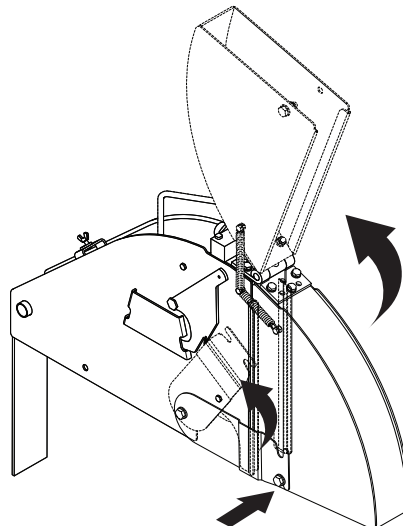

# OPERATING



**WARNING!** Check that the blade, blade flanges and blade flange arbor are undamaged. Clean the contact surfaces of the blade and the blade flanges. Make sure the blade and the flanges are clean and free of dirt and debris before mounting the blade on the machine.

The blade shaft bolt on the right hand side of the saw has left hand threads and the blade shaft bolt on the left hand side of the saw has right hand threads. Replace the blade shaft bolt and plain washer when worn or damaged.

- 1 Loosen blade shaft nut which is used to clamp the blade between the inner and outer flange.
- 2 Remove the outer blade flange.
- 3 Fit diamond blade to blade shaft.
- 4 Install outer flange with blade pre-installed into the inner flange making sure that the locking pin passes through the diamond blade and into the inner flange.

Install and tighten nut using the blade shaft wrench while firmly holding the blade.

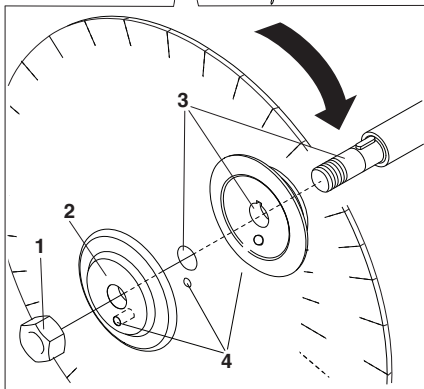
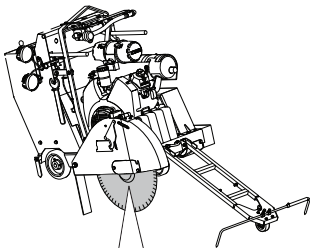

Lower the saw by pushing the Raise/lower switch on the Forward/Reverse control lever downwards until the blade touches the surface to be cut.

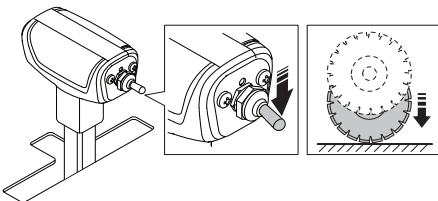

**CAUTION!** The touch should be smooth to prevent damaging the blade. Use Saw lowering speed control knob to slow down the lowering speed. Never let the front weight of the machine be supported by the blade since this will damage the blade.

- Tighten the blade shaft bolt firmly using the blade shaft wrench while resistance between diamond blade and ground helps to achieve proper and final tightening.
- Lower blade guard front and position the blade guard latch on the blade guard front bolt. Tighten the blade guard front bolt.

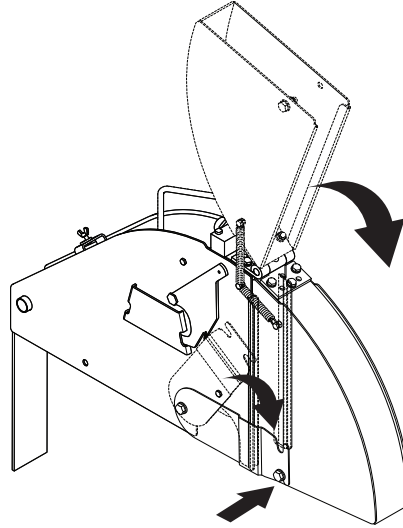

**NOTICE!** Do not operate this saw without the latch engaged and the bolt installed. Do not use if damaged.

- Test run the machine and check that no unusual sounds occur. Unusual sounds are a sign of an incorrectly mounted blade.

## Install the blade guard

Slip on blade guards are secured with a blade guard lock which engages the rear half of the blade guard.

Do not operate this saw without the lock engaged. Inspect blade guards and locks frequently. Do not use if damaged.

Lower the guard onto the support spade and use moderate force to press down the blade guard until lock engages.

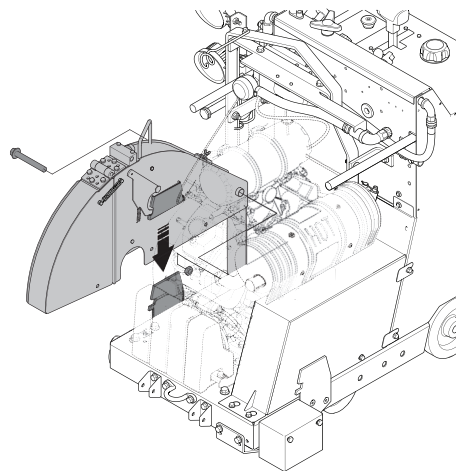

## Remove the blade guard

- 1 Disconnect the water hose from the blade guard.
- 2 Remove the bolt holding the blade guard.

# OPERATING

- 3 Move the blade guard lock forward until it stops and unlatches. Lift the blade guard with its handle off the support spade.

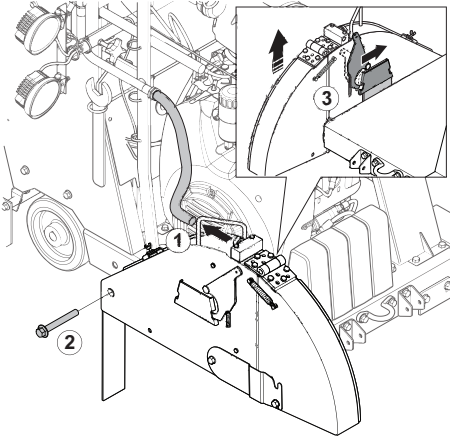

## Blade cutting depth

This saw is equipped with a Blade Depth Indicator which indicates the depth at which the blade is cutting. This saw also includes a Blade Depth Stop which stops the cutting depth of the blade at a specific depth.

For more information about maximum cutting depth for different blade sizes, see section "Blades"

## Use of the Blade Depth Indicator

**NOTICE!** Only saw as deep as the job specifications require since deeper sawing can cause structural strength problems.

- If the engine is running, turn the Engine start switch to the OFF position to stop the engine.
- Turn the engine start switch to the ON position.
- Lower the saw by pushing the Raise/lower switch on the Forward/Reverse control lever downwards until the blade touches the surface to be cut. This will be the reference point.

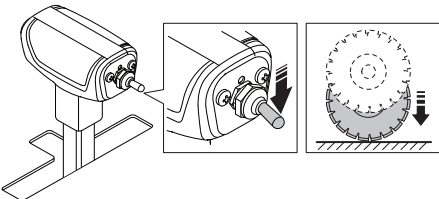

- Rotate the Blade Depth Indicator knob to the zero position. The blade cutting depth will now be indicated on the Depth Indicator when the blade is lowered into the cutting surface.

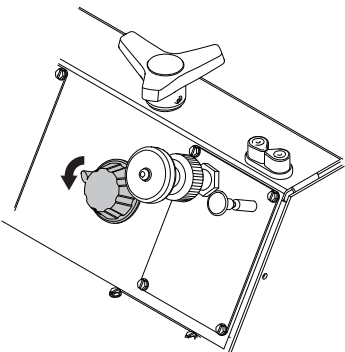

**CAUTION!** The touch should be smooth to prevent damaging the blade. Use Saw lowering speed control knob to slow down the lowering speed.

## Use of the Blade Depth Stop

- Lower the saw by pushing the Raise/Lower switch on the Forward/Reverse control lever downwards until the blade is at the required depth ( as indicated on the Blade Depth Indicator).

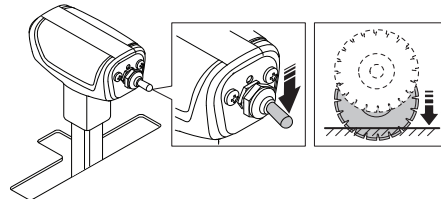

- Set the Blade Depth Stop by turning the knob clockwise until tight. Now the maximum cutting depth is set. If the saw is raised out of the cut surface for any reason it can now be lowered to this specific depth by lowering the blade into the cutting surface with the Raise/Lower switch on the Speed control lever.

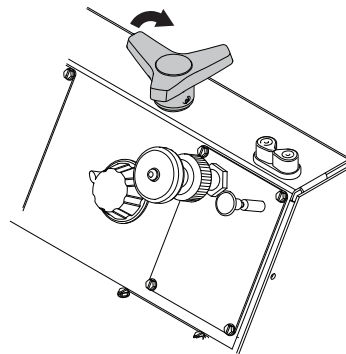

## Straight line sawing

While cutting, the blade is creating resistance to driving force from rear wheels which will cause the machine to yaw in the same direction as the blade is mounted on. This effect can be counteracted by adjusting the angle of the rear axle using the manual axle adjustment.

## Saws with manual axle adjustment

- The rear axle is adjusted by turning the adjustment bolt located at the rear lower left of saw frame with an 18mm wrench.
- If the saw steers to the right while sawing, turn the adjustment bolt counterclockwise.
- If the saw steers to the left while sawing, turn the adjustment bolt clockwise.

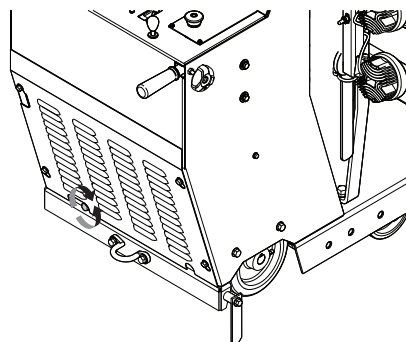

# OPERATING

## Hydraulic System

The hydraulic system on this saw is used to raise/lower the diamond blade and to propel the saw forward or reverse.

The hydraulic system consists of a Hydrostatic Transmission, a DC Lift Pump with a Flow Control Valve and a Hydraulic Lift Cylinder.

- The lowering rate of the saw can be adjusted using the Flow Control Valve. If the saw falls too quickly, turn the knob on the Flow Control Valve clockwise until an adequate lowering rate is set.

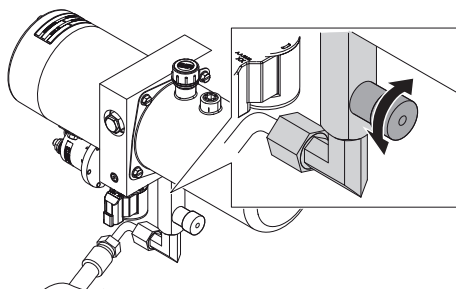

## Transport and storage

- Remove the blade before transportation or storage of the machine, to avoid damage to the blade.
- Remove all adjustment tools and wrenches
- Close the fuel shut-off valve.



**WARNING! Remove the cutting blade prior to lifting, loading, unloading or transporting the machine.**

## Transport



**WARNING! Always remove the cutting blade before transporting the machine outside the cutting area.**



**WARNING! When moving the saw up and down ramps, with engine on, use extreme caution. For steep ramps, always use a winch. Never stand below the machine. Stand only beside.**

- To go down a ramp, drive the saw backwards slowly.
- To go up a ramp, drive the saw forward slowly.

## Lifting the saw

- Observe care when lifting. You are handling heavy parts, which imply the risk of pinch injuries or other injuries.

- Always use the machine mounted lifting eye when lifting.

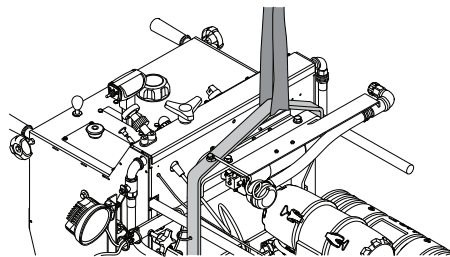

## To transport by vehicle

- Secure the equipment during transportation in order to avoid transport damage and accidents. Use the factory installed tie down lugs on the saw, front and rear to prevent movement during transport.
- Do not tow this saw with another vehicle as this may damage drive components.

## Storage

Store the equipment in a lockable area so that it is out of reach of children and unauthorized persons.

- Stop the engine by turning the Engine start switch to the STOP position.
- Put Forward/Reverse control lever into the Stop/Neutral position.

For transport and storage of fuel and battery, see the section "Fuel handling" and "Battery handling".

For transport and storage of Blades, see the section "Blades".

## Long-term storage

Ensure the machine is cleaned and that a complete service is carried out before long-term storage. Read the engine owner's manual for additional information on long-term storage.

- Remove the blade for storage and store it carefully.

Close the fuel shut-off valve and reinstall the rear protective cover.

- Grease all nipples before storage.
- Disconnect negative terminal and secure in safe distance from battery.
- Trickle charge the battery during long-term storage.
- When storing the machine for long periods the fuel tank must be emptied. Contact your local petrol station to find out where to dispose of excess fuel.
- Store the machine and its equipment in a dry and frost proof place.
- If the machine is stored outside, cover the machine.
- Change engine oil after a long-term storage

# STARTING AND STOPPING

## Before starting



**WARNING!** Please read the operator's manual carefully and make sure you understand the instructions before using the machine.

**Wear personal protective equipment. See instructions under the "Personal protective equipment" heading.**

**Make sure no unauthorised persons are in the working area, otherwise there is a risk of serious personal injury.**

- Perform daily maintenance. See instructions in section "Maintenance and service".
- Check that the blade is not in contact with anything when the machine is started.

**NOTICE!** Read the operator's manual supplied by the engine manufacturer.

## Starting for the first time

- Check engine oil level without blade and the saw horizontal for a flat saw level.
- Connect battery cables. The floor saw unit is supplied with no battery cables connected.

For some markets batteries are not supplied due to safety reason during transportation. Install a new battery.

For more information, see the "Technical data" section.

This machine is equipped with a fuel shut-off valve. To start the machine the first time:

- Fill the fuel reservoir.
- Remove the rear protective cover and open the fuel shut-off valve.

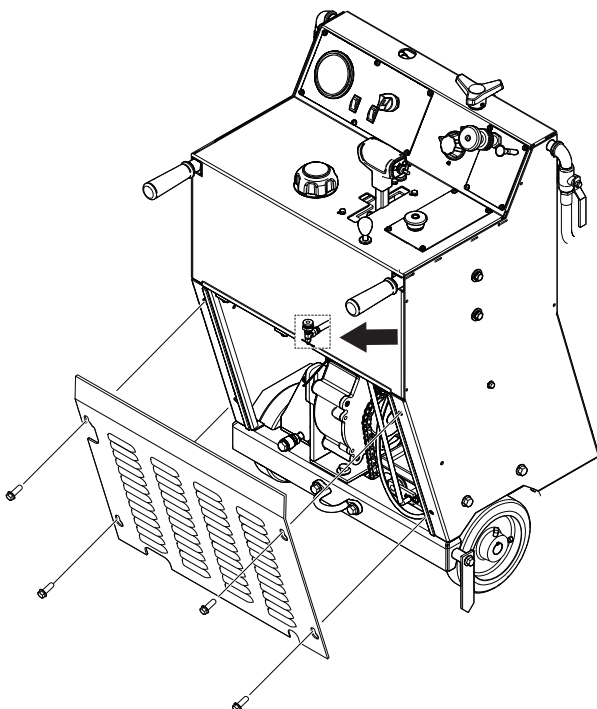

- Reinstall the rear protective cover.

## Starting

- Connect the machine to a water supply. Turn off the Water valve.

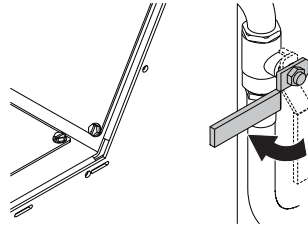

- Mark the surface to be cut by drawing a line where the cut is to be made.
- Pull out handle bars to desired length and tighten the knobs.

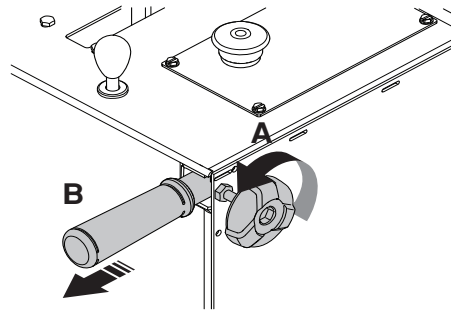

- Lower the front guide and align the front guide, rear guide and the diamond blade with the line on the surface. The front guide is telescopic, adjust the length with the screws on the inside of the front guide.

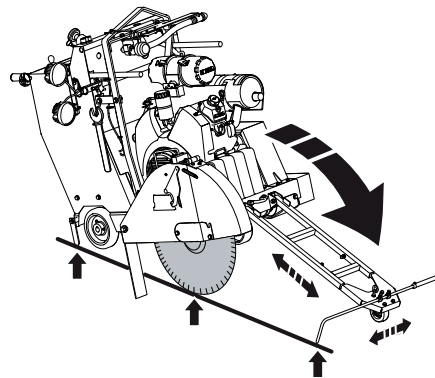

## Start the engine

- To start the saw when no water pressure is present, set the Water safety switch to the OFF position.

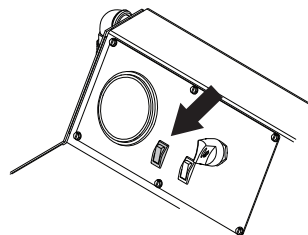

## Water safety system

Water is used to prevent overheating the blade while controlling the dust that results from sawing. The water safety system monitors the water pressure to the machine and interrupts the sawing process if the pressure drops.

# STARTING AND STOPPING

- Set the Forward/Reverse control lever to the Stop/Neutral position. The engine will not start unless the lever is in the distinct Stop/Neutral position.

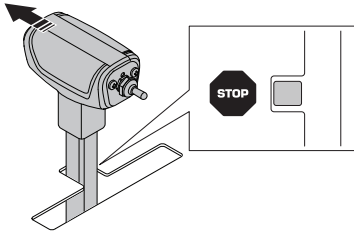

- Start the engine.

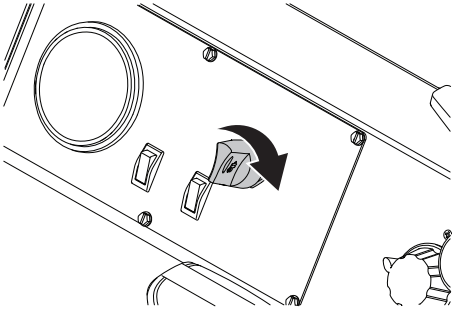

- Let the engine warm up for several minutes with Engine throttle at idle speed (minimum).

Do not warm up the machine outside the cutting area, when the blade is fitted to the machine. To fit the blade, see the instructions under the heading Fitting the blade.

## Start the cutting



**WARNING! Never use a blade with a lower speed rating than that of the machine. Make sure the blade is properly installed.**

**NOTICE! See chart for the appropriate blade shaft and engine speeds for specific blade sizes.**

- Test for adequate water supply. Low water flow will cause damage to diamond blades. Engage the Water safety switch on the control panel and open the Water valve.

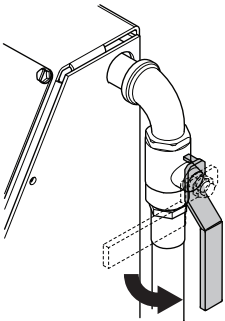

- Shift the Forward/Reverse control lever into gear.

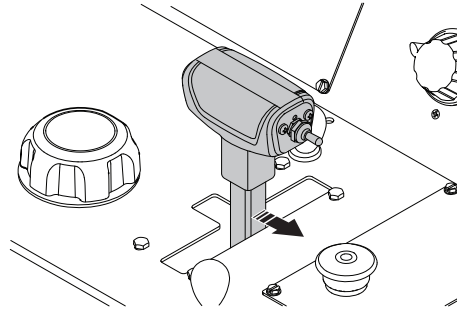

- Set the Engine throttle knob to maximum rpm.
- Lower the blade by pressing the Raise/Lower switch on the Forward/Reverse control lever until the blade is at the desired cutting depth. For more information see section "Blade cutting depth".

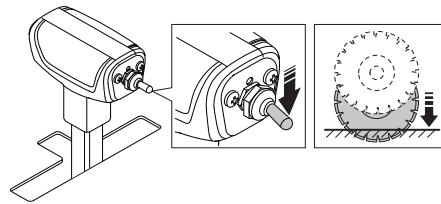

**CAUTION! When lowering the blade into a partial cut, align the blade exactly with the cut to prevent damage to the blade.**

- Move the saw forward slowly by pushing on the Forward/Reverse control lever. Listen to the sound of the engine. If the engine starts to slow down compensate by pulling Forward/Reverse control lever backwards to decrease feeding and prevent stalling the blade. Make sure the front guide, rear guide and diamond blade stays on the line.

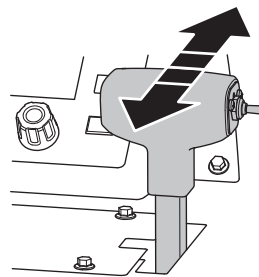

# STARTING AND STOPPING

## Stopping



**WARNING!** Always keep all parts of your body away from blade and all other moving parts.

### Stop the cutting

- Put Forward/Reverse control lever into the Stop/Neutral position.

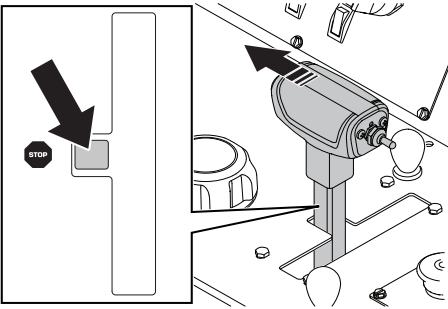

- Raise the diamond blade out of the cut by pressing the Raise/lower switch on the control lever upward until the diamond blade clears the surfaces.

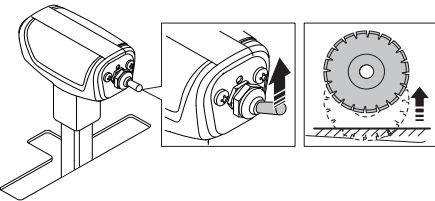

### Stop the engine

- 1 Turn the Engine throttle knob to the low idle position.
- 2 Turn the Water valve off.
- 3 Let the engine run at idle for a few minutes before shutting off. Do this within the cutting area and do not leave the machine unsupervised.
- 4 Stop the engine by turning the Engine start switch to the STOP position.

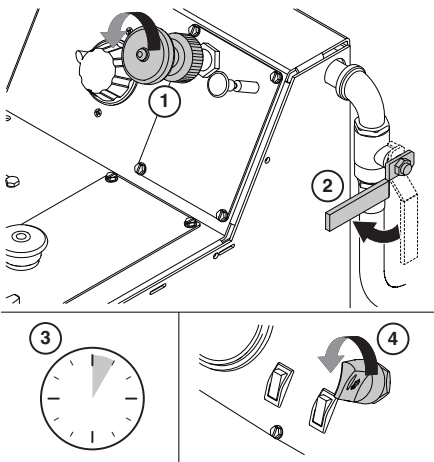

# MAINTENANCE AND SERVICE

## General



**WARNING!** Most accidents involving machines occur during trouble shooting, service and maintenance as staff have to locate themselves within the machine's risk area. Prevent accidents by being alert and by planning and preparing the work.

If servicing operations require the motor to be in operation, be aware of risks when working with or in the vicinity of moving parts.

Perform maintenance and servicing in accordance with this Operator's Manual to avoid shutdowns and to maintain the machine's value.

Maintain the machine's supplementary equipment and tools as well.

The user must only carry out the maintenance and service work described in this Operator's Manual. More extensive work must be carried out by an authorized service workshop.

Use only original spare parts for repairs.

## Measures to take in advance of maintenance, service and trouble shooting

### General

- Ensure that the machine is situated in a safe area.
- Always park the machine on a level surface with the engine OFF and the Engine start switch set in the STOP position before starting. Press the Machine stop on the control panel.
- Several components heat up during use of the machine. Do not commence any servicing or maintenance tasks until the machine has cooled.
- Set out clear signs to inform persons in the vicinity that maintenance work is in progress.
- Ensure that the working area is sufficiently illuminated to create a safe working environment.
- Ascertain the location of fire-extinguishers, medical supplies and emergency telephone.
- Remove the cutting blade before performing maintenance, service or trouble shooting.

### Protective equipment

- Wear personal protective equipment. See instructions under the "Personal protective equipment" heading.

### Working environment

- The area around the machine must be free of dirt in order to minimize the risk of slipping.

## Cleaning



**CAUTION!** When cleaning the machine there is a risk of getting dirt and harmful substances in the eyes, for example.

Dirt and harmful substances can be released from the machine when using high pressure equipment.

High-pressure jetting using water or air can permeate into the skin and cause serious injury. Never aim a high-pressure jet towards the skin.

After each use clean the machine when cooled down.

### Cleaning method

The cleaning method varies depending on type of contaminants and how dirty the machine is. A mild degreasing agent can be used. Avoid skin contact. Use high-pressure washers to clean the machine.

### Cleaning of components

There are a number of components that require special consideration when cleaning.

**NOTICE!** Do not use high-pressure washers to clean the control panel.

### Engine

- Keep a distance of at least 40 cm between the nozzle and engine and its components. Do not spray too aggressively on the engine to prevent damage to electrical components like electrical plugs and alternator. Do not spray water directly in to the exhaust pipe or in engine air filter.

### After washing

- Lubricate all the machine's lubrication points.
- Blow electrical terminals dry using compressed air.
- Let the machine dry thoroughly before start.
- Exercise caution when the machine is started after washing. If any components have been damaged due to moisture, the machine's movements can be defective.



# MAINTENANCE AND SERVICE

## Service schedule

The service schedule is based on the machine's operating time. More frequent service intervals might be necessary when working in dusty or hot environments and in conjunction with work that generates high temperatures. A description of how the operations are to be performed is to be found in the service review.

For certain service requirements, refer to the service intervals in the service schedule below and keep track on the next service. The machine will keep track on the working hours and it can be seen in the display.

- Always park the machine on a level surface with the engine OFF and the Engine start switch set in the STOP position before performing any maintenance. Press the Machine stop on the control panel.

Please read the engine manual for your machine carefully and make sure you understand the instructions before using the machine. There are some maintenance intervals specified in the engine manual.

In case where same services operation is recommended both in this machine's operator manual and in the engine operator manual, follow the schedule recommendations given in this manual.

## Daily maintenance

Daily maintenance must also be carried out after transportation.

	Daily	50h	100h	250h	500h	Yearly
Check for fuel and oil leakage.	X					
Check the engine's oil level	X					
Check blade guard for damage	X					
Check hoses and clamps for damage or looseness. Tighten or replace as required.	X					
Check air cleaner restriction indicator. Clean outer air filter if indicator is red.	X					
Make sure all safety guards are in place and in good condition.	X					
Check the water spray over the diamond blade.	X					
Replace engine oil and filter*		X				
Lubricate front wheels		X				
Lubricate blade shaft (2 pumps each end)		X				
Check the drive belt for wear.		X				
Replace engine oil and filter*			X			
Lubricate front axle pivot bearings			X			
Check wheels for wear or damage.			X			
Check rear wheels for looseness			X			
Check engine air cleaner hose and clamps			X			
Check hydraulic system fluid level			X			
Lubricate hydraulic cylinder pivot pin.				X		
Lubricate rear axle bearing.				X		
Replace hydraulic system fluid					X	
Replace engine fuel filter (spin-on-type)					X	
Replace outer and inner air filter						X

\* Once at 50h then every 100h

# MAINTENANCE AND SERVICE

## Daily maintenance



**WARNING! Switch off the engine before carrying out any checks or maintenance.**

Check engine oil level without blade and the saw horizontal for a flat saw level.

- Check the engine oil level.
- Make sure the level is between the limits.

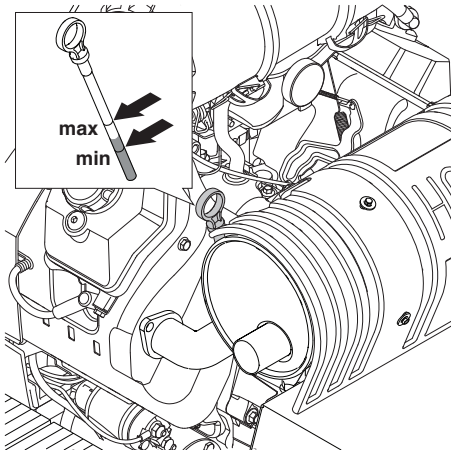

## Check blade guard for damage

- Check the blade guard for cracks.

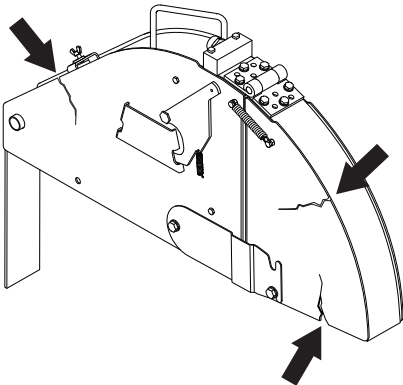

- Never use a broken or damaged blade guard.

## Check all hoses and clamps for damage or looseness.

The image only shows some of the hoses and clamps.

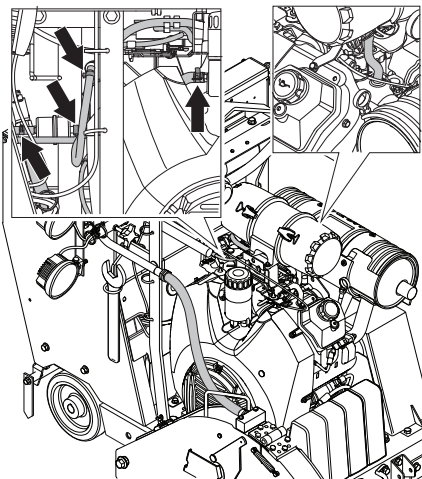

- Look for leakage on fuel and hydraulics system. Tighten or replace as necessary.

## Check air cleaner restriction indicator.

- Check and clean the outer air filter if the air cleaner indicator is red, remove the rear cover by opening the 2 air filter housing clamps and pulling the housing off.

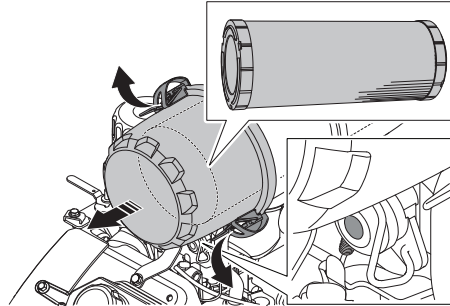

- Clean the filter by blowing the element from inside out. Use the lowest possible air pressure to remove the dust without damaging the element. Use 0,29-0,49 MPa; 3,0-5,0 kgf/cm<sup>2</sup> (42-47 PSI) compressed air to remove particulates.

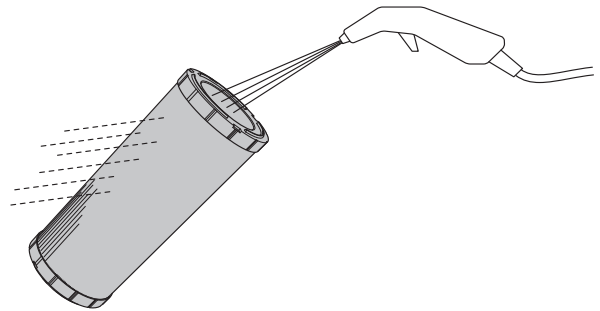

- Replace any damaged filters or gaskets and check air hose and clamps for damages or looseness. Tighten or replace as required.

**NOTICE! No need to clean the inner filter on a daily basis. The 2 air filter housing clamps can not be closed unless the outer air filter is properly installed.**

## Protection covers

- Make sure all protection covers are in place and in good condition.

For more information, see the "Machine's safety equipment" section.

# MAINTENANCE AND SERVICE

## Check the water spray over the diamond blade.

- Raise blade guard front and use quick release pin to lock it in upright position.

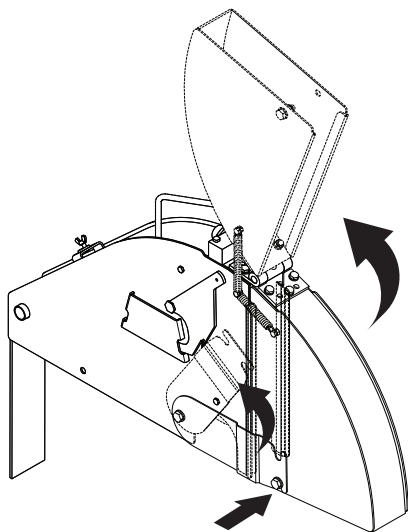

- Open the Water valve on the control panel. Make sure it is straight jets of water out of the holes from the water pipes on both sides of the blade and no leakage. Replace water pipe if damaged.

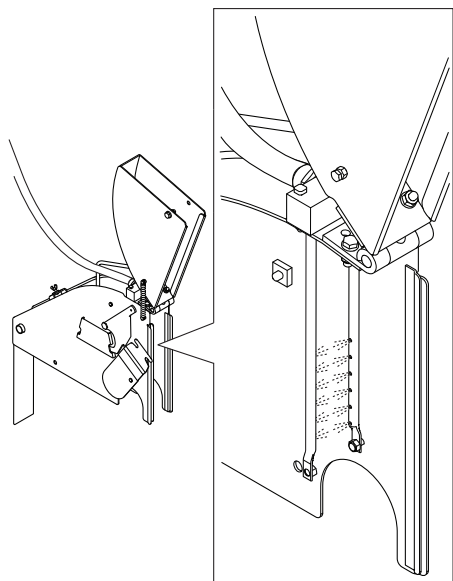

## After the first 50 hours

### Replace engine oil and filter

- Remove the top cap from the hose. Open the valve and bend it down to empty the system.  
Remove the filter and replace it.  
Lubricate the seal with a few drops of oil prior to refitting it.

**NOTICE!** Protect the battery from oil spill prior to removing and refitting.

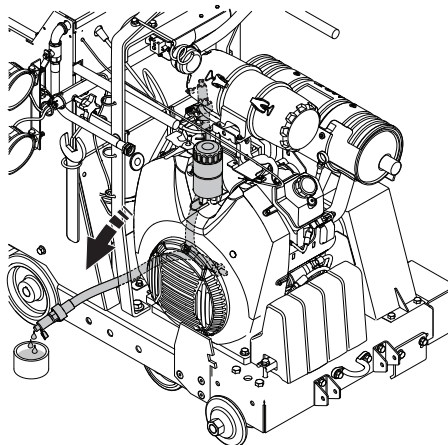

- Refill the system with oil.

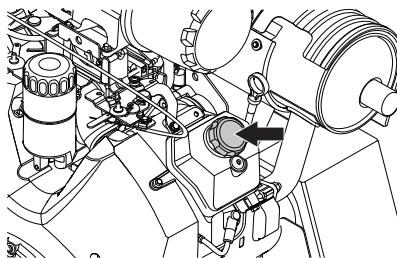

- Check the engine's oil level, see instructions under heading "Daily maintenance".

## 50 hours service

### Automatic blade shaft drive belt tensioning

This machine is equipped with a dynamic belt tension device that does not require any adjustment or maintenance.

Correct tension is preset during production assembly. However, if replacement of belt or other components are needed please follow below 6 steps for correct procedure.

### Tools required

- 13 mm. wrench (not included with machine)
- 19 mm. wrench (not included with machine)
- Adjustable wrench (not included with machine)
- Allen key, 8 mm (not included with machine)

### To release belt tension

- Use 13 mm. wrench to open 4 M8 bolts that attach belt guard. Remove belt guard.
- Use the allen key to remove allen screw (securing screw).

# MAINTENANCE AND SERVICE

- Use 19 mm. wrench to slightly loosen the screw that fix the tension device to the plate.

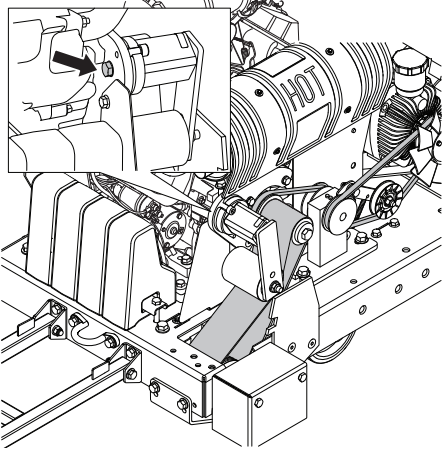

## To set correct tension

- Use an adjustable wrench to turn the base of the tension device in counter clock wise direction to set required pre tension. When angle on tension device shows 25° and the slot on base of the tension device is aligned with hole in plate: tighten the fixing screw using a 19 mm. wrench.
- Reinstall the allen screw by using an allen key.
- Reinstall belt guard. Use 13 mm. wrench to tighten 4 M8 bolts that fix belt guard.



**CAUTION! Always replace Polly-V belts if worn or damaged.**

## Lubricate blade shaft (2 pumps each end)

See instructions under the heading "Lubrication".

## Lubricate front wheels

See instructions under the heading "Lubrication".

## 100 hours service

### Replace engine fuel filter (In-line type)

- Close the fuel shut-off valve on the fuel tank. Remove the fuel filter by unsnapping it from the fuel line. Replace the fuel filter. Beware of fuel that may spill.

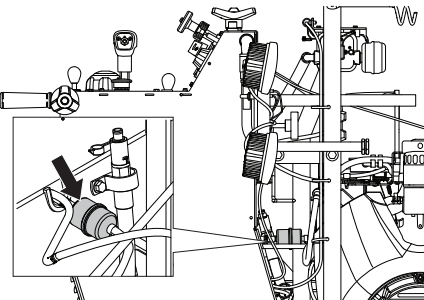

### Replace engine oil and filter

See instructions under the heading "After the first 50 hours"

### Check wheels for wear or damage.

Check rear wheels for looseness

## Check engine air cleaner hose and clamps

### Check hydraulic system fluid level

- Remove the plug in the inspection opening on the hydraulic reservoir. The level should be to the bottom edge of the opening on the hydraulic reservoir, fill if necessary.

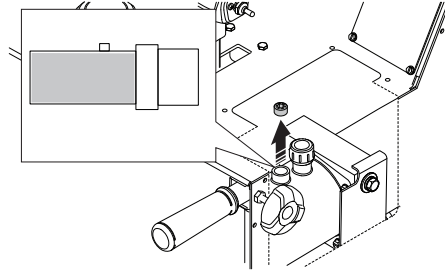

**NOTICE! Do not overfill!**

### Lubricate front axle pivot bearings

See instructions under the heading "Lubrication".

## 250 hours service

### Lubricate hydraulic cylinder pivot pin.

See instructions under the heading "Lubrication".

### Lubricate rear axle bearing.

See instructions under the heading "Lubrication".

## 500 hours service

### Replace hydraulic system fluid

- Remove the plug in the inspection opening on the hydraulic reservoir and use an oil extractor to suck out the fluid through the inspection opening.

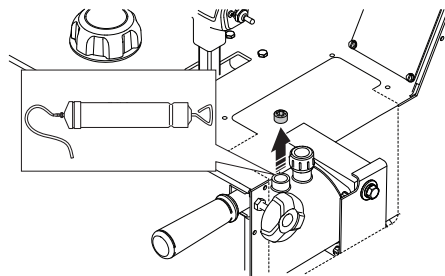

# MAINTENANCE AND SERVICE

- Refill the reservoir with new oil. Ensure that machine is level prior refilling.

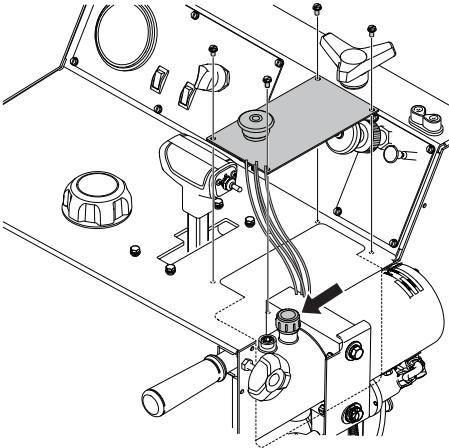

**NOTICE!** Do not overfill!

## Yearly maintenance

### Replace outer and inner air filter

Remove the rear cover by opening the 2 air filter housing clamps and pulling the housing off. Replace both filters and refit them in reverse order.

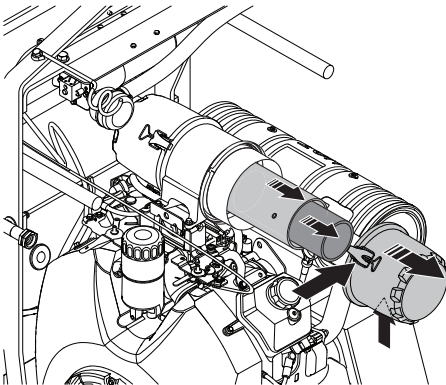

**CAUTION!** The 2 air filter housing clamps can not be closed unless the outer air filter is properly installed.

## Lubrication

The image shows all the lubrication points (8 grease nipples). Clean the nipple. Replace broken or blocked nipples.

- Lubricate the front wheels.
- Lubricate the front axle pivot bearings.
- Lubricate the blade shaft. Two pumps at each end.
- Lubricate hydraulic cylinder pivot pin.
- Lubricate rear axle bearing.

Lubricate blade shaft on top of the base plate.

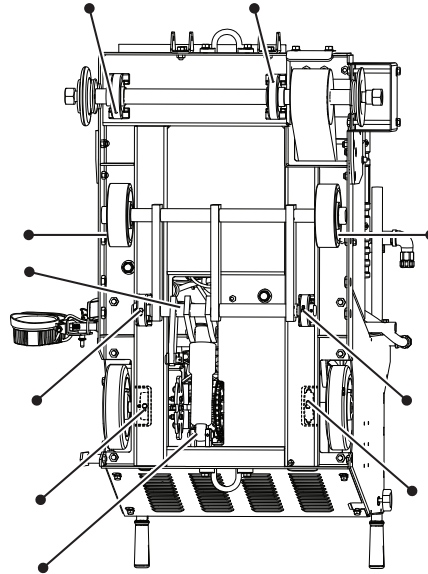

# TROUBLESHOOTING

## Incidents during sawing

**CAUTION!** If the engine or blade stops for any reason, raise the blade completely from the cut. Set the Engine start switch to STOP position. Press the Machine stop on the control panel. Inspect the machine thoroughly before restarting the engine.

- Entrust all repairs to your authorized dealer only

Problem	Cause	Possible action
Engine stops during sawing	Engine out of fuel.	Refill with fuel
	Lack of water signals the Water safety switch to stop the engine	Disengage the Water safety switch and check water supply, then restart the engine.
	The Machine stop has been pressed down	Reset the machine stop by pulling the knob outward.
	Excessively fast cutting will stall the engine	Listen to the sound of the engine. If the engine starts to slow down compensate by pulling Forward/Reverse control lever backwards to decrease feeding and prevent stalling the blade.
	Circuit breaker fuse is blown	Inspect and replace fuses
The diamond blade stops during sawing	Drive belt tension is inadequate	The ROSTA tensioner or drive belt needs to be replaced.
Saw lowers too fast	The valve that controls the saw lowering is open too much.	The lowering rate of the saw can be adjusted using the Saw lowering speed control knob on/under the hydraulic pump. If the saw lowers too quickly, turn the knob clockwise until an adequate lowering rate is set.
The blade cuts too slowly.	The blade has become dull or it is too high feeding pressure	Decrease the cutting depth and engine speed for a short time

---

# TECHNICAL DATA

---

## Battery

	<b>FS 3500 G</b>
Terminal type	Standard SAE
Voltage, V	12
CCA, A	475
Maximum size (LxWxH), mm/inch	242x175x175 / 9 9/16x6 7/8x6 7/8

## Hydraulic fluid and lubricants

### Hydraulic fluid

<b>Quality</b>	<b>Standard</b>
SAE 10W-30	API Class SE
	API Class CC
	API class CD

### Lubricants

Component	Quality	Standard	Oil tank capacity, litre/qt
Engine oil	SAE 10W-30	API Class SJ	2/1,9
Hydrostat Pump	SAE 10W-30		0,19/0,18
Lift Pump	SAE 10W-30		0.95/1.0
Transmission Gearbox	NLGI 000		
Lubrication points (baseplate)*	NLGI 000	SAE J310	

\* See instructions in section "Maintenance and service".

# TECHNICAL DATA

## Technical data

### FS 3500 G

Saw feature	500/20	650/26	750/30
Blade guard capacity, mm/inch	500/20	650/26	750/30
Maximum cutting depth, mm/inch	193/7,75	262/10,5	312/12,5
Blade shaft, rpm	2580	1860	1860
Approximate blade shaft output, hp/kW	29/21,6		
Arbor size, mm/inch	25,4/1 with single drive pin		
Blade flange Ø, mm/inch	114,5/4,5	127/5	127/5
Blade shaft diameter, mm/inch	36,5 / 1-7/16		
Blade shaft bearings	Pillow block ball bearings 17/16"		
Blade shaft drive	Polly-V belt (25 ribs)		
Blade coolant	Zinc plated dual multiple-jet water spray tubes		
Blade guard attachment	Slip-on, auto-latch		
Blade control	Electro-hydraulic pump raises blade; Switch controlled raise/lower on speed control handle; Depth stop and cutting depth indicator.		
Axle Ø, mm/inch	Front, 25,4/1		
	Rear, 25,4/1		
Wheels, mm/inch	Front, 152x51x25/6x2x1, thick polyurethane tread, sealed ball bearing requiring less maintenance		
	Rear, 203x51x25/8x3x1, solid rubber		
Transmission	Hydrostatic pump coupled to mechanical gear box, chain final drive		
Max. ground speed	Infinitely variable: 0-51m/min / 0-167 fpm forward and reverse. 25m/min maximum reverse speed on CE models		
Chassis	Heavy duty, rigid, box and channel section construction		
Weight (uncrated), kg/lb	441/972	446/983	450/992
Maximum operating mass, kg/lb	455/1003	463/1021	470/1036



# TECHNICAL DATA

## Saw dimensions

A	Width, mm/inch		807 / 31 3/4	H	Saw length (pointer up, handles extended), mm/inch	1977 / 77 3/4
B	Center to center wheel width, mm/inch	Front	502 / 19 3/4	J	Min. overall height (no exhaust pipe, no pre-cleaner cap), mm/inch	1152 / 45 3/8
		Rear	540 / 21 1/4			
C	Outside to outside wheel width, mm/inch	Front	553 / 21 13/16	L	Wheel base length, mm/inch	464 / 18 1/4
		Rear	591 / 23 1/4	M	Guard to handle length (handles in), mm/inch	1549 / 61
D	Frame width, mm/inch		606 / 23 7/8	N	Max. overall length (handles in), mm/inch	2210 / 87
E	Inner flange to inner flange width, mm/inch		670 / 26 3/8	O	Max. overall length (handles extended, pointer down), mm/inch	2895 / 114
F	Handle extension, mm/inch		809 / 31 7/8	P	Max. overall length (handles extended, pointer extended), mm/inch	3378 / 133
G	Min. saw length (handles removed, pointer and guard up), mm/inch		1168 / 46			

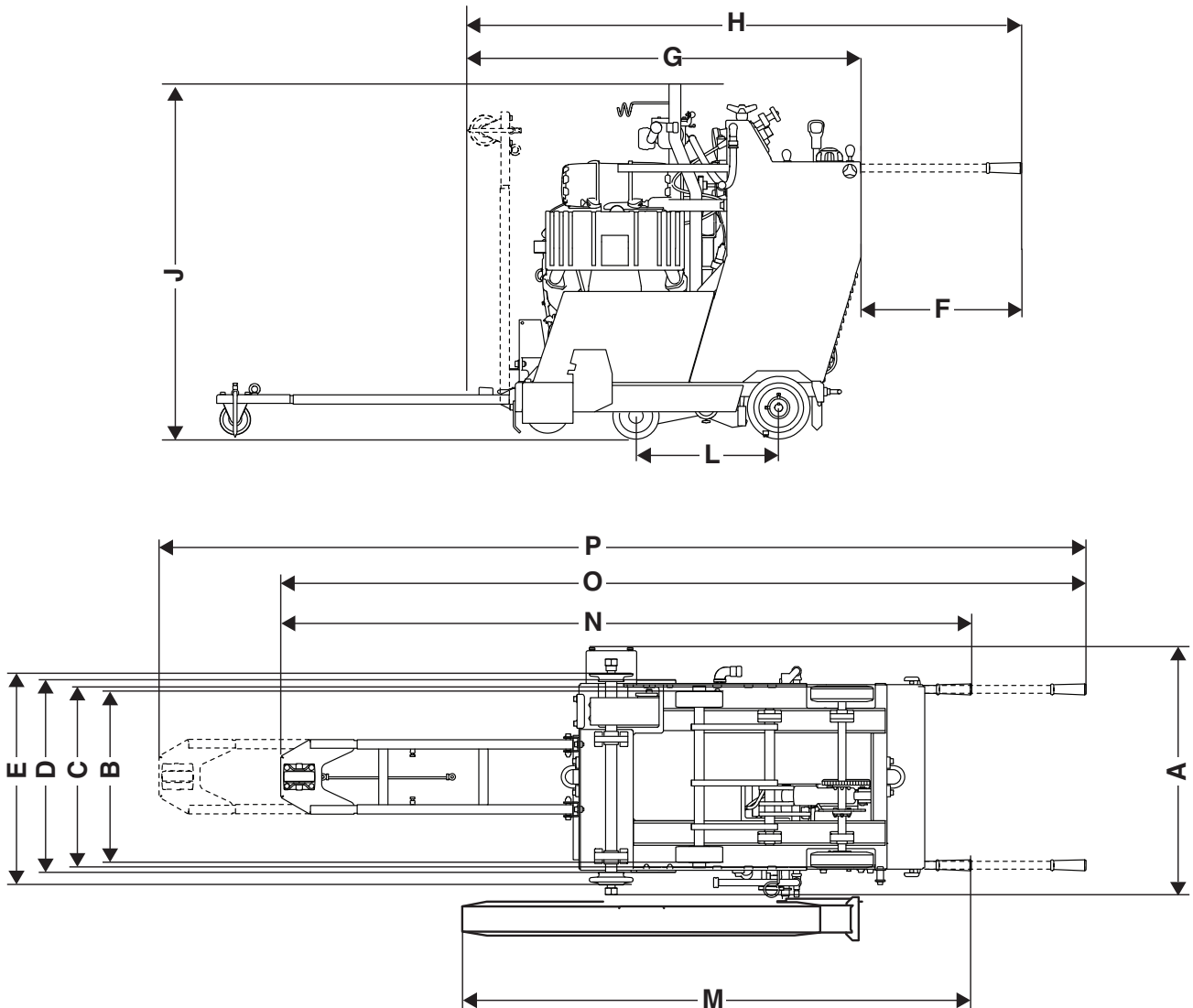

---

# TECHNICAL DATA

---

## Engine FS 3500 G

Engine specifications	Kohler CH1000
Max. engine output (see note 1)	37hp@3750rpm (27.5kW@3750rpm)
Displacement, dm <sup>3</sup> / cu.in.	1,0 / 61
Cylinders	2
Stroke, mm / in.	78,5 / 3.1
Fuel tank capacity, l / gallon	23,8 / 6.3
Air filter	Cyclon air filter and restriction indicator
Starter	Electric

For further information and questions about this specific engine please see, [www.kohlerengines.com](http://www.kohlerengines.com).

Note 1: As specified by engine manufacturer. The power rating of the engines indicated is the average net power output (at specified rpm) of a typical production engine for the engine model measured to ISO3046, SAE J1940/J1995. Mass production engines may differ from this value. Actual power output for the engine installed in the final machine will depend on the operating speed, environmental conditions and other variables.

## Noise emissions

	FS 3500 G
<b>Noise emissions (see note 1)</b>	
Sound power level, measured dB(A)	107
Sound power level, guaranteed L <sub>WA</sub> dB(A)	110
<b>Sound levels (see note 2)</b>	
Sound pressure level at the operators ear, dB(A)	95
<b>Vibration levels, a<sub>hv</sub> (see note 3)</b>	
Handle right, m/s <sup>2</sup>	1,6
Handle left, m/s <sup>2</sup>	3,8

Note 1: Noise emissions in the environment measured as sound power (L<sub>WA</sub>) in conformity with EC directive 2000/14/EC. The difference between guaranteed and measured sound power is that the guaranteed sound power also includes dispersion in the measurement result and the variations between different machines of the same model according to Directive 2000/14/EC.

Note 2: Noise pressure level according to EN 13862. Reported data for noise pressure level has a typical statistical dispersion (standard deviation) of 4.0 dB(A).

Note 3: Vibration level according to EN 13862. Reported data for vibration level has a typical statistical dispersion (standard deviation) of 1 m/s<sup>2</sup>.

# RELAYS AND FUSES

## Relays and fuses - FS 3500 G

Function		Designation	Ampere
Main system		-F1	30
Hydraulic System		-F2	5
Engine carb solenoid		-F3	5
Tachometer		-F4	2
Lights	(optional)	-F5	10
Water pump	(optional)	-F6	10
Main relay		-K1	20
Supress relay		-K2	10
Oil sentry relay		-K3	5

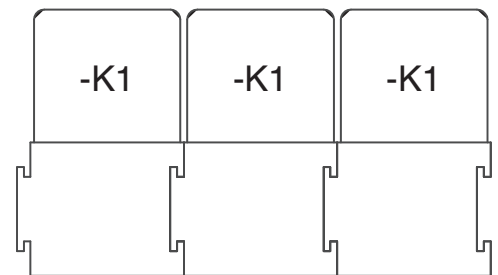
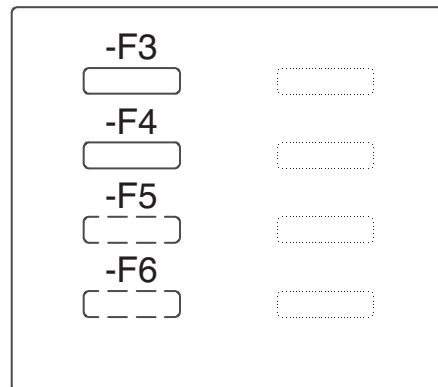
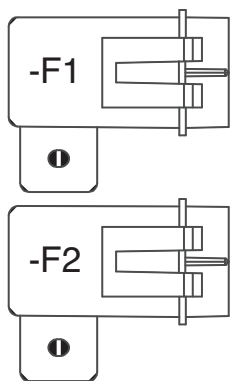

---

# EC DECLARATION OF CONFORMITY

---

## EC Declaration of Conformity

### (Applies to Europe only)

**Husqvarna AB**, SE-561 82 Huskvarna, Sweden, tel +46-36-146500, declares under sole responsibility that the flat saws **Husqvarna FS 3500 G** from 2016's serial numbers and onwards (the year is clearly stated in plain text on the rating plate with subsequent serial number), complies with the requirements of the COUNCIL'S DIRECTIVES:

- of May 17, 2006 "relating to machinery" **2006/42/EC**.
- of February 26, 2014 "relating to electromagnetic compatibility" **2014/30/EU**.
- of May 8, 2000 "relating to the noise emissions in the environment" **2000/14/EC**.

The following standards have been applied: **EN ISO 12100:2010, CISPR12:2007+Amd1:2009, EN55012:2008+A1:2009, EN13862+A1:2009, EN ISO 14982:2009, ISO 13766:2006.**

Notified body: 0404, SMP Svensk Maskinprovning AB, Box 7035, SE-750 07 Uppsala, Sweden, has performed voluntary type examination in accordance with the machinery directive (2006/42/EC) on behalf of Husqvarna AB. The certificate has the number: **SEC/16/2457**

Gothenburg 26 February 2016

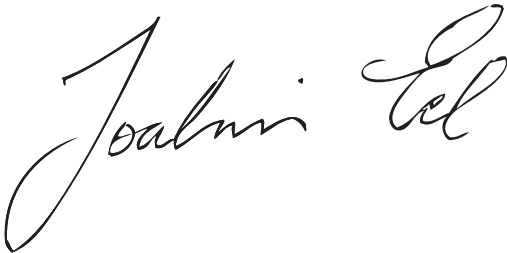

Joakim Ed

Global R&D Director

Construction Equipment Husqvarna AB

(Authorized representative for Husqvarna AB and responsible for technical documentation.)









[www.husqvarnacp.com](http://www.husqvarnacp.com)

Original instructions



1157588-26

2016-09-09