

metabo®

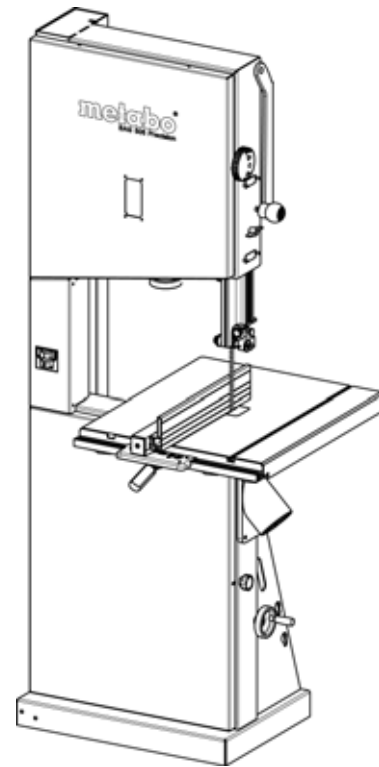

BAS 505 Precision



(D)	Originalbetriebsanleitung	3
(ENG)	Original operating instructions	15
(F)	Instructions d'utilisation originales	27
(NL)	Origineel gebruiksaanwijzing	39

1. Parts Identification

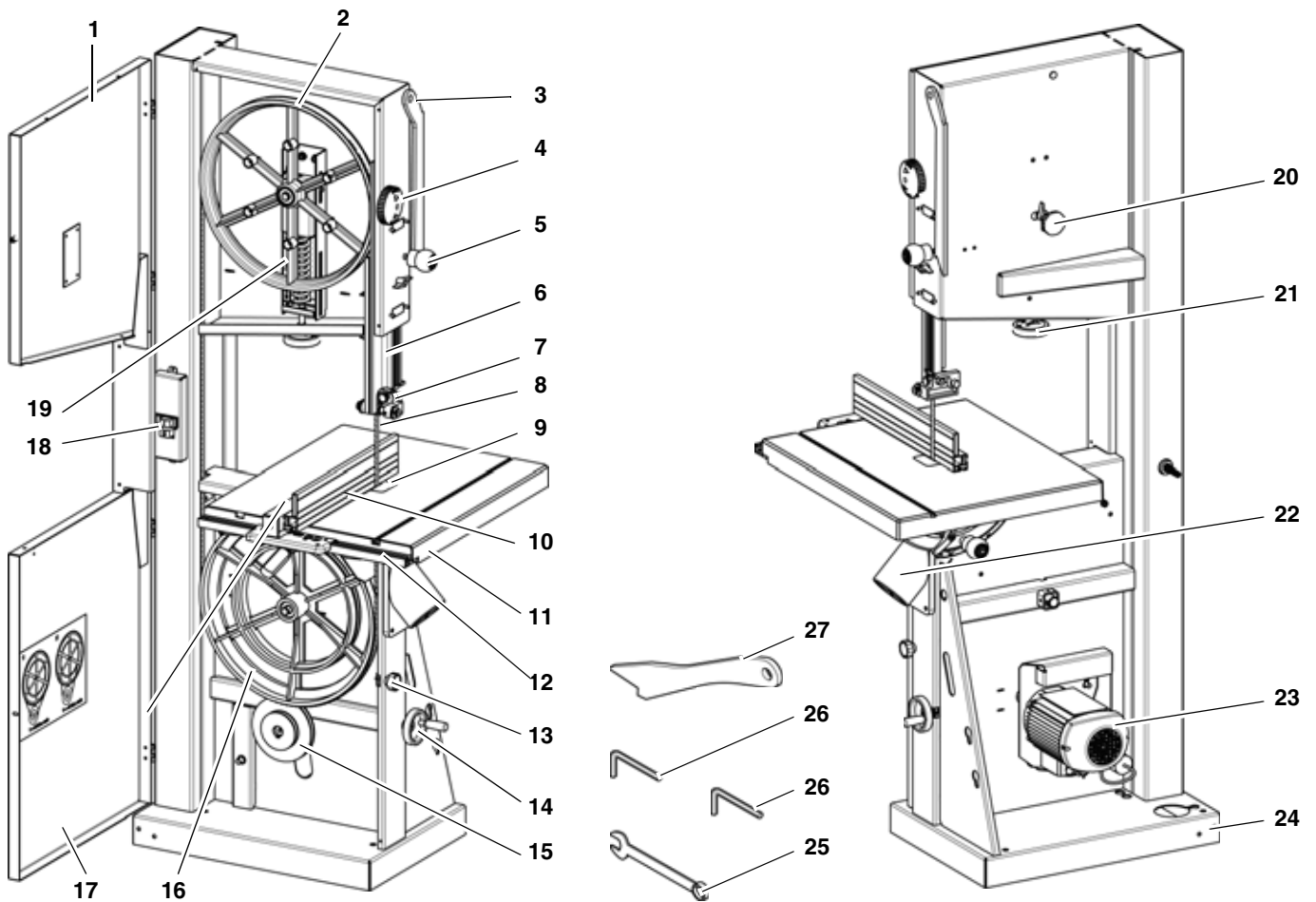

Front

- 1 Upper housing door
- 2 Upper band saw wheel
- 3 Push stick holder
- 4 Turn-lock fastener, housing door
- 5 Twist handle for blade guard
- 6 Blade guard
- 7 Blade guide, upper
- 8 Band saw blade
- 9 Table insert
- 10 Rip fence
- 11 Saw table
- 12 Fence guide extrusion
- 13 Turn-lock fastener, housing door

- 14 Twist handle for V-belt tension setting
- 15 V-belt drive
- 16 Lower band saw wheel
- 17 Lower housing door
- 18 On/Off switch with emergency stop
- 19 Blade tension indicator

Rear

- 20 Setting knob for blade tracking adjustment
- 21 Setting knob for band saw blade tension
- 22 Dust extraction port
- 23 Motor
- 24 Machine base
- 25 Wrench
- 26 Allen key
- 27 Push stick

Table of Contents

1. **Parts Identification**.....15
 2. **Please Read First!**16
 3. **Initial Operation**.....16
 4. **Safety**16
 4.1 Specified conditions of use16
 4.2 General Safety Instructions.....16
 4.3 Symbols on the machine.....18
 4.4 Safety devices.....18
 5. **Transport**18
 6. **Machine details**18
 6.1 Aligning the saw table19
 6.2 Mounting20
 6.3 Installing the Saw Table20
 6.4 Tensioning the Band Saw Blade ...20
 6.5 Fence guide extrusion installation20
 6.6 Rip fence installation20
 6.7 Dust collector connection20
 6.8 Changing the Band Saw Blade ...20
 6.9 Mains connection21
 7. **Operation**21
 7.1 Adjusting the Upper Blade Guide22
 7.2 Sawing22
 8. **Care and Maintenance**22
 8.1 Band saw blade alignment23
 8.2 Upper blade guide alignment23
 8.3 Aligning the Lower Blade Guide....23
 8.4 Replacing the Band Saw Tyre.....24
 8.5 Replacing the Table Insert24
 8.6 Saw Cleaning.....24
 8.7 Saw storage24
 9. **Tips and Tricks**.....24
 10. **Available Accessories**24
 11. **Repairs**24
 12. **Environmental Protection**.....24
 13. **Trouble shooting**.....24
 14. **Technical specifications**.....25
 14.1 Available Band Saw Blades26

2. Please Read First!

These operating instructions have been written to make it easier for you, the user, to learn how to operate this machine and to do so safely. These instructions should be used as follows:

- Read instructions before use. Pay special attention to the safety information.
- These instructions are intended for persons with basic technical knowledge regarding the operation of a device like the one described herein. If you have no experience whatsoever, you are strongly

advised to seek competent advice and guidance from an experienced person before operating this machine.

- Keep all documents supplied with this machine for future reference. Retain your proof of purchase in case of a future warranty claim.
- If you lend or sell this machine be sure to have these instructions go with it.
- The equipment manufacturer is not liable for any damage resulting from neglect of these operating instructions.

Information in this manual is denoted as follows:



Danger!
Risk of personal injury or environmental damage.



Risk of electric shock!
Risk of personal injury by electric shock.



Drawing-in/trapping hazard!
Risk of personal injury by body parts or clothing being drawn into the rotating saw blade.



Caution!
Risk of material damage.



Note:
 Additional information.

- At times numbers are used in illustrations (1, 2, 3, ...). These numbers
 - indicate component parts;
 - are consecutively numbered;
 - correspond with the number(s) in brackets (1), (2), (3) ... in the neighbouring text.
- Numbered steps must be carried out in sequence.
- Instructions which can be carried out in any sequence are marked with a bullet (•).
- Listings are indicated by an En Dash (-).

3. Initial Operation



Danger!
Start the saw only after the following preparations have been completed:

- **saw is mounted;**
- **saw table is installed and aligned;**
- **the V-belt tension checked;**

- **safety devices have been checked.**
- **Connect the saw to the mains supply only after all of the above preparations are completed! Otherwise there is a risk of an unintentional starting of the saw, which can cause severe personal injury.**

4. Safety

4.1 Specified conditions of use

This machine is intended for indoor use in dry rooms only. Any outdoor use is not permitted!

The machine is suitable for cutting wood, wood-derived materials and plastics.

Do not cut round stock transverse to its longitudinal axis without suitable jigs or fixtures. The rotating saw blade could turn the work piece.

When sawing thin stock layed on edge, a suitable guide must be used for firm support.

Any other use is not as specified. The manufacturer is not liable for any damage caused by unspecified use.

Modification of the machine or use of parts not approved by the equipment manufacturer can cause unforeseeable damage!

4.2 General Safety Instructions

- When using this machine observe the following safety instructions, to minimize the risk of personal injury or material damage.
- Please also observe the special safety instructions in the respective sections.
- Where applicable, follow the legal directives or regulations for the prevention of accidents pertaining to the use of band saws.

General hazards!

- Keep your work area tidy – a messy work area invites accidents.
- Be alert. Know what you are doing. Set out to work with reason. Do not operate device while under the influence of drugs, alcohol or medication.
- Consider environmental conditions. keep work area well lighted.
- Prevent adverse body positions. Ensure firm footing and keep your balance at all times.
- Use suitable workpiece supports when cutting long stock.

- Do not operate the machine near inflammable liquids or gases.
- The machine shall only be started and operated by persons familiar with bandsaws and who are at any time aware of the dangers associated with the operation of such machine.

Persons under 18 years of age shall use this device only in the course of their vocational training, under the supervision of an instructor.

- Keep bystanders, particularly children, out of the danger zone. Do not permit other persons to touch the machine or power cable while it is running.
- Do not overload device – use it only within the performance range it was designed for (see “Technical Specifications”).



Danger! Risk of electric shock!

- Do not expose machine to rain. Do not operate the machine in damp or wet environment. Prevent body contact with earthed objects such as radiators, pipes, cooking stoves, refrigerators when operating this device.
- Do not use the power cable for any purpose it is not intended for.



Risk of injury by moving parts!

- Do not operate the machine without installed guards.
- Always keep sufficient distance to the band saw blade. Use suitable feeding aids if necessary. Keep sufficient distance to driven components when operating the electric tool.
- Wait for the band saw blade to come to a complete stop before removing cutoffs, scrap, etc. from the work area.
- Cut only stock of dimensions that allow for safe and secure holding while cutting.
- Do not attempt to stop the band saw blade by pushing the workpiece against its side.
- Ensure the tool is disconnected from power before servicing.
- When turning ON the machine (e.g. after servicing) ensure that no tools or loose parts are left on or in the machine.
- Unplug the tool when not in use.



Cutting hazard, even with the cutting tool at standstill!

- Wear gloves when changing cutting tools.
- Store band saw blades in such manner that nobody will get hurt.



Risk of kickback (workpiece is caught by the band saw blade and thrown against the operator)!

- Do not jam workpieces.
- Cut thin or thin-walled work pieces only with fine-toothed band saw blades. Always use sharp band saw blades.
- If in doubt, check workpiece for inclusion of foreign matter (e.g. nails or screws).
- Cut only stock of dimensions that allow for safe and secure holding while cutting.
- Never cut several workpieces at the same time – and also no bundles containing several individual pieces. Risk of personal injury if individual pieces are caught by the band saw blade uncontrolled.
- When cutting round stock, use a suitable jig to prevent the workpiece from turning.



Drawing-in/trapping hazard!

- Ensure that no parts of the body or clothing can be caught and drawn in by rotating components (**no** neckties, **no** gloves, **no** loose-fitting clothes; contain long hair with hairnet).
- Never saw workpieces containing the following materials:
 - ropes
 - strings
 - cords
 - cables
 - wires.



Danger due to insufficient personal protection equipment!

- Wear hearing protection.
- Wear safety goggles.
- Wear dust mask.
- Wear suitable work clothes.
- When working outdoors wearing of non-slip shoes is recommended.



Risk of injury by inhaling wood dust!

- Some types of wood dust (e.g. oak, beech and ash) may cause cancer when inhaled. Work only with a suitable dust extractor attached to the saw. The dust collector must comply

with the specifications stated in the Technical Data.

- Make sure that as little as possible wood dust can escape into the environment:
 - remove wood dust deposit in the work area (do not blow away!);
 - fix any leakages on the dust collector;
 - keep your work area well ventilated at all times.



Hazard generated by modification of the machine or use of parts not tested and approved by the manufacturer!

- Strictly follow these instructions when assembling the device.
- Use only parts approved by the manufacturer. This applies especially for:
 - band saw blades (see “Technical Specifications” for stock nos.);
 - safety devices (see "Spare parts list" for stock numbers).
- Do not change any parts.



Hazard generated by tool defects!

- Keep device and accessories in good repair. Observe the maintenance instructions.
- Prior to any use check the machine for possible damage: before operating the machine all safety devices, protective guards or slightly damaged parts need to be checked for proper function as specified. Check to see that all moving parts work properly and do not jam. All parts must be correctly installed and meet all conditions necessary for a proper operation of the device.
- Before switching on: Check if saw blade coasts down for more than 10 seconds; if more than 10 seconds, have motor replaced by a qualified electrician.
- Damaged protection devices or parts must be repaired or replaced by a qualified specialist. Have damaged switches replaced by a service centre. Do not operate tool if the switch cannot be turned ON or OFF.
- Keep handles free of oil and grease.



Danger from blocking workpieces or workpiece parts!

If blockage occurs:

1. Switch machine OFF.
2. Unplug mains cable.
3. Wear gloves.
4. Clear blockage with suitable tool.

4.3 Symbols on the machine



Danger!

Disregard of the following warnings could lead to serious personal injury or material damage.



Read instructions.



Unplug mains cable.



Band saw blade running direction.

Information on the nameplate:

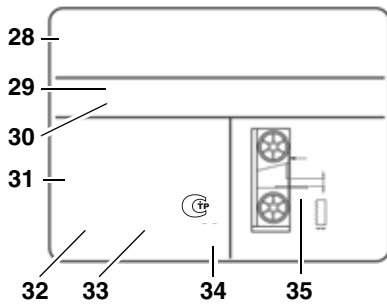

- 28 Manufacturer
- 29 Serial number
- 30 Machine designation
- 31 Motor specifications (see also "Technical Specifications")
- 32 CE mark – This machine meets the EC directives as per declaration of conformity
- 33 Waste disposal symbol – Device can be disposed of by returning it to the manufacturer
- 34 Date of manufacture
- 35 Dimensions of approved band saw blades

4.4 Safety devices

Upper blade guard

The upper blade guard (37) protects against unintentional contact with the saw blade and from chips flying about.

In order for the upper blade guard to provide adequate protection against contact with the band saw blade, it must always be set as close as possible against the workpiece (max. distance 3 mm).

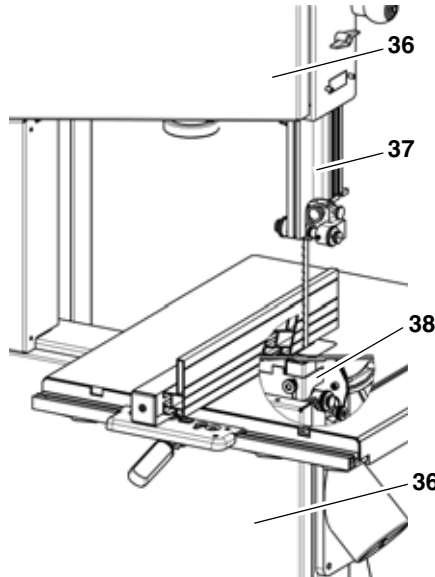

Lower blade guard

The lower blade guard (38) protects against inadvertent contact with the band saw blade below the saw table.

The lower blade guard must be installed during operation.

Housing doors

The housing doors (36) protect against contact with the rotating parts inside the machine.

The housing doors are equipped with interlocking contacts. These turn the motor OFF when one housing door is opened while the saw is running.

The housing doors must be closed while the machine is in use.

Push stick

The push stick serves as an extension of the hand and protects against accidental contact with the saw blade.

The push stick must always be used if the distance between band saw blade and a rip fence is less than 120 mm.

Guide the push stick at an angle of 20° ... 30° against the saw table's surface.

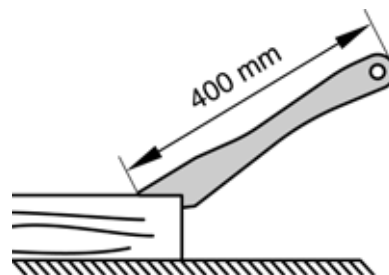

When the push stick is not used, it can be stored on the push stick holder provided at the band saw frame.

Replace the push stick if damaged.

5. Transport

- Set upper blade guide to its lowest position.
- Remove projecting accessories.

- Transport the saw with the help of a second person.
- For transport use the original packing where possible.

6. Machine details

i Note:

In this chapter the essential operating elements of the machine are introduced.

The proper use of the saw is detailed in chapter "Operation". Read this chapter before using the saw for the first time.

ON/OFF switch

- To start = press green switch button (39).
- To stop = press red switch button (40).

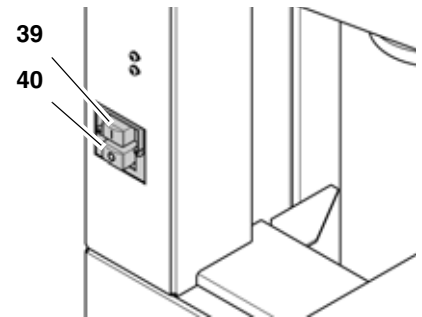

In the event of a power failure an under-voltage relay will trip. This prevents the starting of the machine when the power is restored. To restart, the green switch button must be pressed.

Turn-lock fastener, housing door

Open and close the housing door using the turn-lock fastener (41).

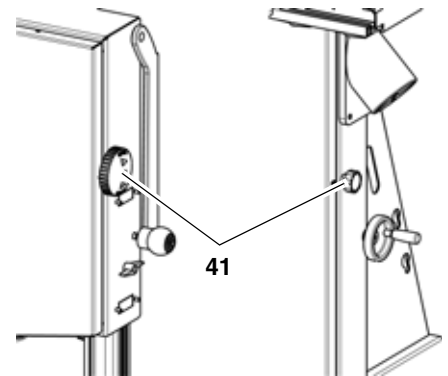

Opening the housing door:

1. Rotate the upper turn-lock fastener clockwise approx. one turn and the lower turn-lock fastener anticlockwise approx. one turn.

The housing door opens slightly. This activates the door interlock which switches the motor off.

⚠ Danger from exposed bandsaw blades and wheels!

If after one turn the motor does not switch off or the door immediately opens wide, the door interlock or the closure system is defective. Shut down the saw and return it to the Service Centre in your country for repair.

2. Rotate the turn-lock fastener further.
The housing door opens wide.

Closing the housing door:

- Press on the housing door and rotate the upper turn-lock fastener anticlockwise and the lower turn-lock fastener clockwise all the way.

The housing door is completely contacting the housing.

Setting knob for band saw blade tension

With the setting knob (42) the band saw blade tension is corrected, if necessary:

- Turning the setting knob clockwise increases the blade tension.
- Turning the setting knob counter-clockwise reduces the blade tension.

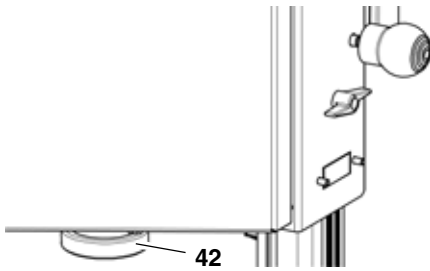

Setting knob for blade tracking adjustment

With the setting knob (43) the tilt of the upper band saw wheel can be adjusted, if necessary. This tracking adjustment is required to have the blade run dead centre on the rubber tyres of the band saw wheels:

- turning clockwise = blade moves to the rear
- Turning counter-clockwise = blade moves to the front.

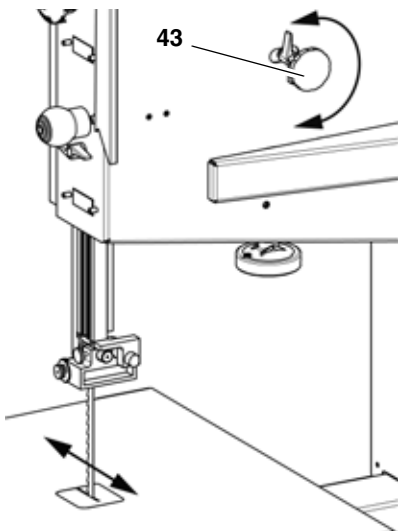

Setting knob for drive belt tension

With the setting knob (44) the drive belt tension is corrected, if necessary:

- Turning the adjustment knob anti-clockwise decreases the blade tension.
- Turning the setting knob clockwise increases the blade tension.

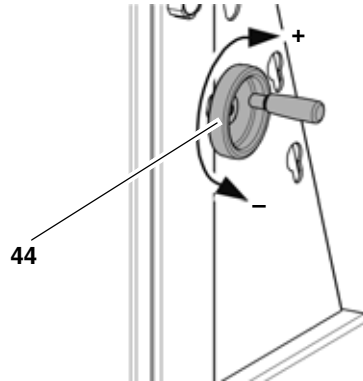

Saw table tilt

After loosening the locking screw (46) the saw table (45) tilts steplessly through 20° against the blade.

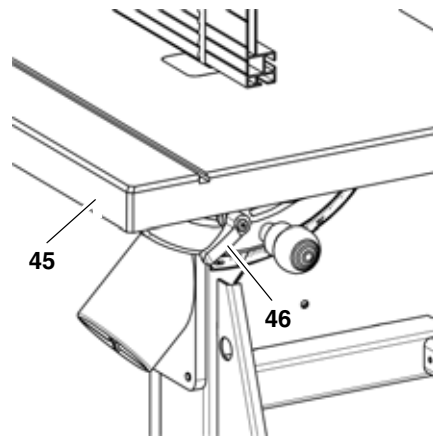

Rip fence

The rip fence (47) is clamped to the front. The rip fence can be used on both sides of the blade.

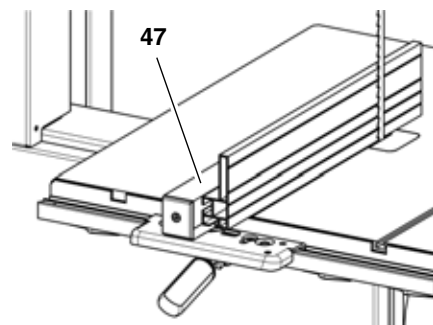

6.1 Aligning the saw table

The saw table needs to be aligned in two planes

- laterally, in order for the blade to run dead centre through the table insert;
- at right angles to the band saw blade.

Saw table lateral alignment

1. Loosen lock lever (48) and hexagon nut (49).

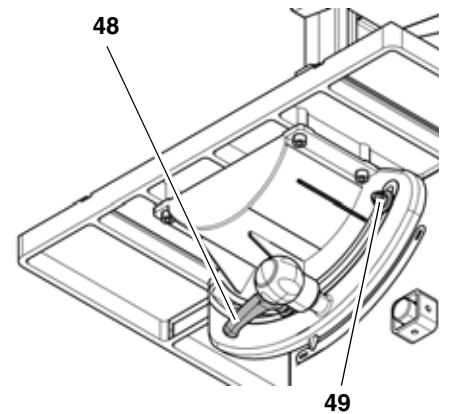

⚠ Danger!

Risk of injury, even with the band saw blade at standstill. To loosen and tighten the fastening screws use a tool that allows for keeping your hand at a sufficient distance from the band saw blade.

2. Loosen the four fastening screws (50).

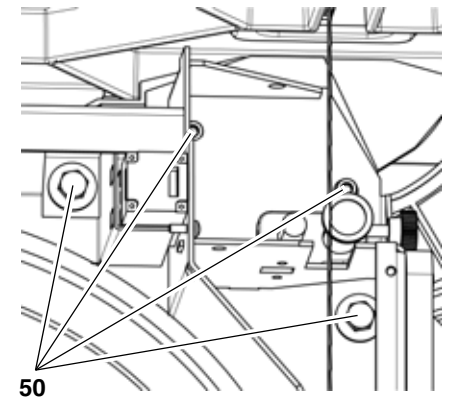

3. Align saw table so that the blade runs through the centre of the table insert's slot.
4. Tighten the four fastening screws (50) again.
5. Tighten hexagon nut (49) only so much that the saw table can still easily be tilted.
6. Tighten lock lever (48).

Aligning the saw table at right angles to the band saw blade

1. Raise upper blade guide fully (see "Operation").
2. Check band saw blade tension (see "Care and Maintenance").
3. Loosen lock lever (48).
4. Using a try square, set the table at right angles to the blade and tighten the lock lever (48) again.
5. Loosen locking nut (51) and adjust limit stop screw (52) until it touches the saw housing.

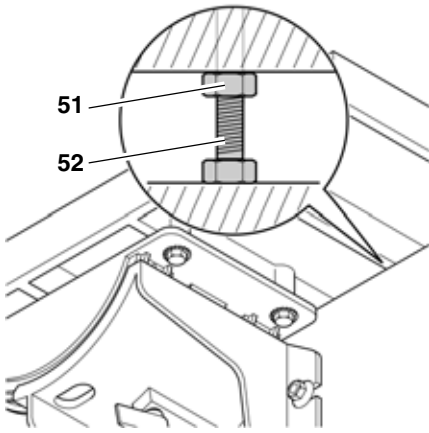

6. Tighten locking nut.

6.2 Mounting

For a firm stand the saw must be mounted on a stable supporting floor:

1. Drill four holes in the supporting floor.

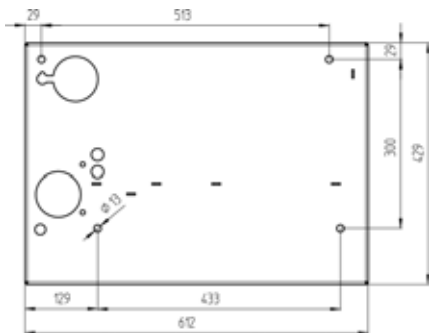

2. Put fixing bolts through the base plate and secure with nuts.

6.3 Installing the Saw Table

1. Fit limit stop screw (53) to the underside of the saw table.
2. Guide saw table over the band saw blade and place it on the table trunnion.
3. Attach the saw table with four each screws (54) and washers to the table trunnion.

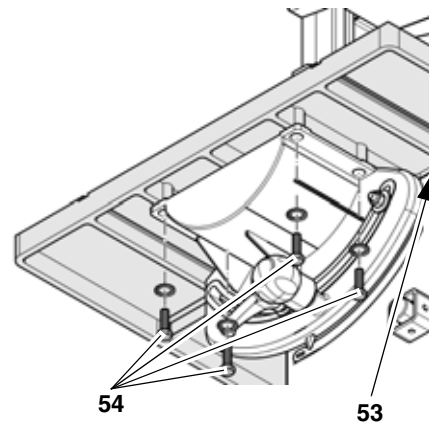

6.4 Tensioning the Band Saw Blade



Danger!

Too much tension can cause the band saw blade to break. Too little tension can cause the driven band saw wheel to slip and the band saw blade to stop.

1. Raise upper blade guide fully (see "Operation").
2. Checking the blade tension:
 - Check tension by pushing with a finger, halfway between table and upper blade guide, against the side of the blade (the blade should flex not more than 1-2 mm).
 - Check adjustment at the blade tension indicator. The scale indicates the correct adjustment in dependence on the band saw blade width.
3. Correct tension if necessary:
 - turning the setting knob (55) counter-clockwise increases the blade tension.
 - turning the setting knob (55) counter-clockwise reduces the blade tension.

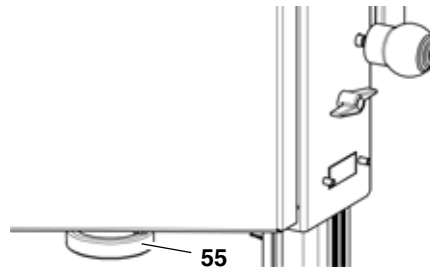

6.5 Fence guide extrusion installation

- Fasten the fence guide extrusion (56) with four thumb screws and washers to the saw table.

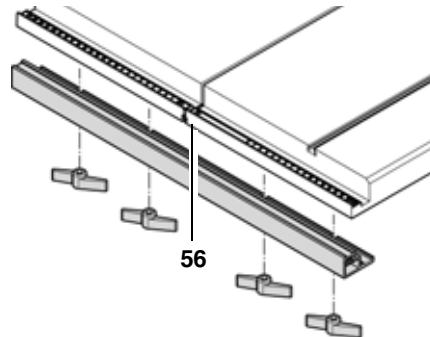

6.6 Rip fence installation

The rip fence can be used on both sides of the blade.

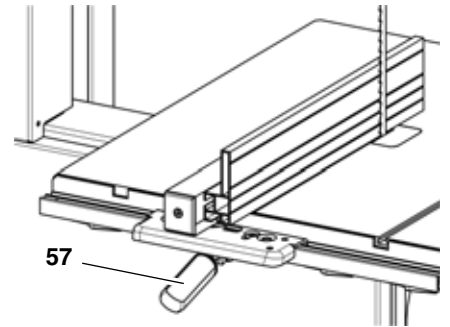

1. Place rip fence on rip fence guide.
2. Tighten lock lever (57) of rip fence.

6.7 Dust collector connection



Danger!

Some types of saw dust (e.g. of oak, beech and ash wood) can cause cancer when inhaled: always use a dust collector when working indoors (required air speed at the saw's suction connector ≥ 20 m/s).



Caution!

Operation without a dust collector is only possible:

- outdoors;
- for short-term operation (up to 30 minutes maximum);
- with dust respirator.
- If no dust collector is used chips will accumulate, which need to be removed periodically.

Connect dust collector or industrial vacuum with a suitable adaptor to the dust extraction port.

6.8 Changing the Band Saw Blade



Danger!

Risk of injury, even with the band saw blade at standstill. Wear gloves when changing blades.

Use only suitable band saw blades (see "Technical specifications").

1. Loosen the four thumb screws and remove the fence guide extrusion (58) for the rip fence.

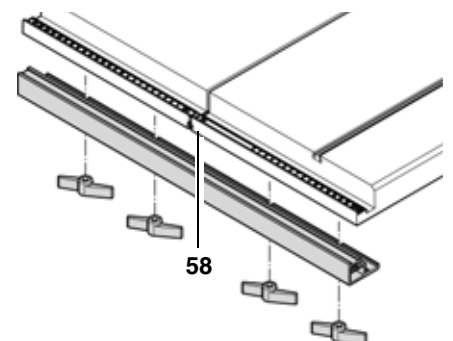

2. Open housing door.

- Adjust upper blade guide (59) to its lowest position.

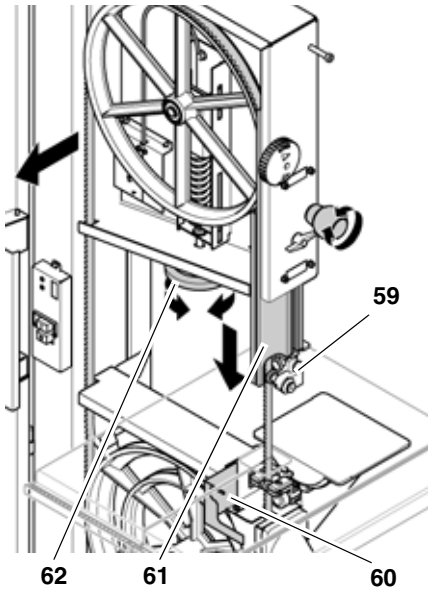

- Loosen knurled nut (63) on the hand guard and slide hand guard into its lower position.

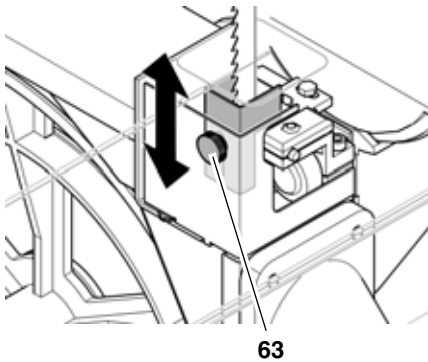

- Open the lower blade guard (60).
- Loosen setting knob (62) until the band saw blade has slackened.
- To remove the band saw blade, guide it through
 - the slot in the saw table,
 - the blade guard on the upper blade guide (61),
 - the lower blade guard (60) and
 - the blade guides.



Danger!

Use a suitable transport device to transport wide clamped saw blades.

- Fit fresh band saw blade. Observe correct position: the teeth point towards the front (door) side of the saw.
- Center band saw blade on the rubber tyres of the band saw wheels.
- Tighten setting knob (62) until blade does no longer slip off the band saw wheels.
- Clamp band saw blade (see section "Clamping the band saw blade").
- Close lower blade guard (60) and slide hand guard into upper position

or against the table's edge, tighten knurled nut (63).

- Close housing door.
- Then:
 - align band saw blade (see section "Aligning the band saw blade");
 - align blade guides (see "Care and maintenance");
 - let saw test run for at least one minute;
 - stop saw, unplug and recheck settings.
- Fasten the fence guide extrusion (58) to the saw table with the four thumb screws and washers.

6.9 Mains connection



Danger! High voltage

- Operate saw in dry environment only.
- Operate saw only on a power source matching the following requirements (see also 'Technical Data'):
 - mains voltage and system frequency conform to the voltage and frequency shown on the device's name plate;
 - fuse protection by a residual current operated device (RCD) of 30 mA sensitivity;
 - outlets properly installed, earthed, and tested;
 - three-phase outlets with neutral wire installed;



Note:

Check with your local Electricity Board or electrician if in doubt whether your house service connection meets these requirements.

- Position power supply cable in a way that it does not interfere with the work and is not damaged.
- Protect power supply cable from heat, aggressive liquids and sharp edges.
- Use only rubber-insulated extension cables of sufficient lead cross section (3 x 1.5 mm², for machines with 3-phase motor: 5 x 1.5 mm²).
- Do not pull on power supply cable to unplug.



change of direction of rotation (only for version with AC motor):

This can lead to the workpiece being hurled away when attempting to make a cut. The direction of rotation must therefore be checked every time the saw is connected to another outlet.

If the direction of rotation is incorrect, the electrical connection must be changed by a qualified electrician!

- After the saw and all of its safety devices have been assembled, connect it to the mains supply.
- Start saw and switch OFF immediately.
- Observe the correct rotational direction of the band saw blade: **In the cutting area the band saw blade must run downwards.**
- If the band saw blade turns in the wrong direction, unplug the power supply cable at the saw.
- Have the electric supply changed by a qualified electrician!

7. Operation



Danger!

To reduce the risk of personal injury as much as possible, the following safety recommendations should be observed when operating the saw.

- Use personal protection equipment:
 - dust respirator;
 - hearing protection;
 - safety goggles.
- Cut only one work piece at a time.
- Always hold the work piece down on the table.
- Do not jam the workpiece.
- Do not attempt to stop the band saw blade by pushing the workpiece against its side.
- Sawing of bowed or irregular work pieces: hold the workpiece firmly against the table and feed in at a uniform speed. Keep your hands in the safe area.
- If the type of work requires, use the following:
 - push stick – if distance rip fence – band saw blade less than ≤120 mm;
 - work support – for long stock, which would otherwise fall off the table on completion of the cut;
 - dust collector;
 - a circle cutting device when cutting circular pieces;
 - a guide when cutting small wedges;
 - an appropriate jig when cutting round stock, to keep it from turning;

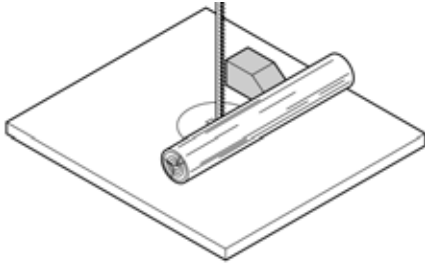

– a suitable guide for firm support when cutting thin stock layed on edge.

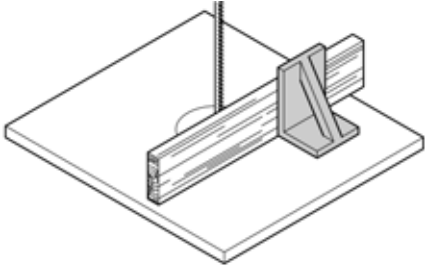

- Before starting work, check to see that the following are in proper working order:
 - band saw blade;
 - upper and lower blade guard.
- Replace damaged parts immediately.
- Assume correct work position (the band saw blade's teeth must point towards the operator).
- Never cut more than one workpiece at a time – and also no bundles containing several individual pieces. Risk of personal injury if individual pieces are caught by the saw blade uncontrolled.

⚠ Drawing-in/trapping hazard!

- Do not wear loose clothing, jewelry, or gloves, which may get caught and wound up by revolving machine parts.
- Contain long hair with a hairnet.
- Never cut stock to which ropes, cords, strings, cables and wires are attached or which contain such materials.

7.1 Adjusting the Upper Blade Guide

The height of the upper blade guide (66) needs to be adjusted:

- prior to every cutting operation, to accommodate the height of the workpiece (the upper blade guide should be set approx. 3 mm above the workpiece);
- after adjustments of band saw blade or saw table (e.g. band saw blade change, tensioning of the band saw blade, saw table alignment).

⚠ Danger!

Turn the machine OFF and wait for the band saw blade to stop before adjusting the upper blade guide or the saw table.

1. Loosen screw (65).
2. Set the upper blade guide (66) with the twist handle (64) to the desired height.

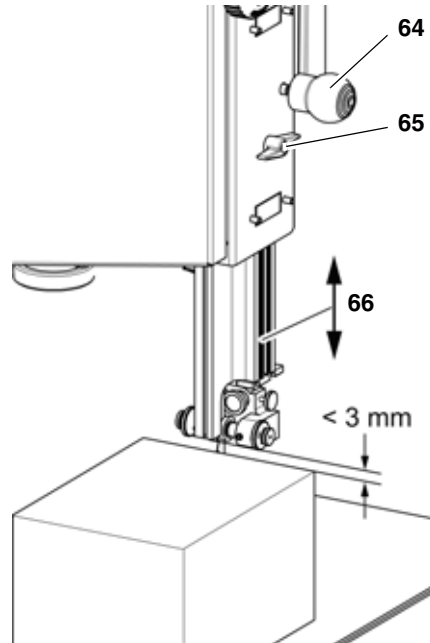

3. Re-tighten screw (65).

Cutting speed adjustment

1. Open the lower housing door.
2. Slacken the V-belt by turning the tension crank handle anticlockwise.
3. Put V-belt on the required pulley of the driving wheel (lower band saw wheel) and the corresponding motor pulley – note label inside the lower housing door.

⚠ Caution!

The V-belt must run either on both front or both rear pulleys. Never have the V-belt run diagonally!

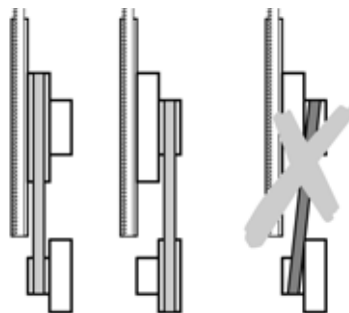

408 m/min 965 m/min

- V-belt on front pulley = low speed, high torque.
- V-belt on rear pulleys = high speed, low torque.

4. Re-tighten the V-belt by rotating the crank clockwise (the V-belt must be able to be depressed in the middle about 10 mm).
5. Close the lower housing door.

7.2 Sawing

1. Check the band saw blade tension (see 'Tensioning the band saw blade').
2. If necessary, adjust the table tilt.
3. Select rip fence and table tilt for the type of cutting operation to be carried out.

⚠ Hazard generated by a jamming workpiece!

When sawing with the rip fence and a tilted saw table, the rip fence must be installed on that side of the saw table which is tilted downward.

4. Set upper blade guide 3 mm above the workpiece.

i Note:

Always make a trial cut in a piece of scrap to verify settings; correct if necessary before cutting the workpiece.

5. Place workpiece on the saw table.
6. Start saw.
7. Cut workpiece in a single pass.
8. Switch off if no further cutting is to be done immediately afterwards.
9. If no further cutting is to be done immediately afterwards: decrease the bandsaw blade tension and attach a notice indicating that the bandsaw blade tension must be reset prior to the next cutting operation to the machine (see 'Tensioning the bandsaw blade').

8. Care and Maintenance

⚠ Danger!

Prior to all servicing:

1. switch machine OFF;
2. Wait for saw blade to stop
3. Unplug mains cable.
 - Check that all safety devices are operational again after each service.
 - Replace damaged parts, especially safety devices, with genuine replacement parts only, since parts not tested and approved by the manufacturer can cause unforeseeable damage.
 - Repair and maintenance work other than described in this section should only be carried out by qualified specialists.



Danger!

If the table insert is damaged, small objects may get caught between the table insert and the kerf plate and block the saw blade. Replace damaged table inserts immediately!

Speed adjustment

By shifting the drive belt the band saw can be operated at two speeds (see "Technical specifications"):

- 408 m/min for hard wood, plastics and non-ferrous metals (with special band saw blade);
- 965 m/min for all kinds of wood.

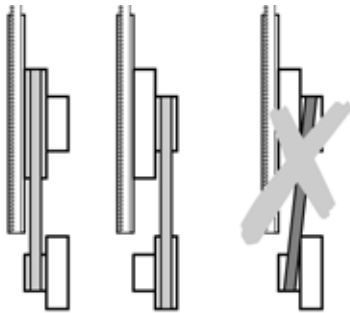

408 m/min 965 m/min



Caution!

The drive belt must not run in a diagonal position; this will damage the belt

8.1 Band saw blade alignment

If the band saw blade does not run in the centre of the rubber tyres, the tracking needs to be corrected by adjusting the tilt of the upper band saw wheel:

1. Loosen lock nut (68).
2. Setting knob (67):
 - Turn setting knob (67) clockwise if the band saw blade runs towards the front of the saw.
 - Turn setting knob (67) counter-clockwise if the band saw blade runs towards the rear of the saw.

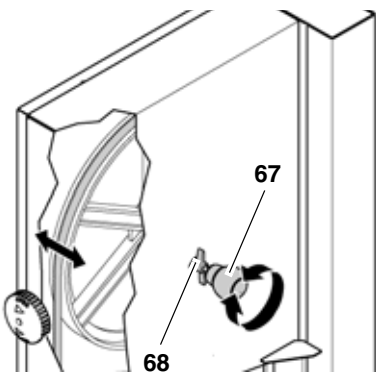

3. Tighten locking nut (68).

8.2 Upper blade guide alignment

The upper blade guide consists of:

- a thrust bearing (supports the band saw blade from the rear),
- two guide bearings (providing lateral support).

All bearings need to be readjusted after every band saw blade change or tracking.



Note:

Periodically check all bearings for wear, if necessary replace both guide bearings at the same time.

Adjusting the thrust bearing

1. If necessary, align and tighten the band saw blade.
2. Loosen the thrust bearing's (69) lock screw (70).

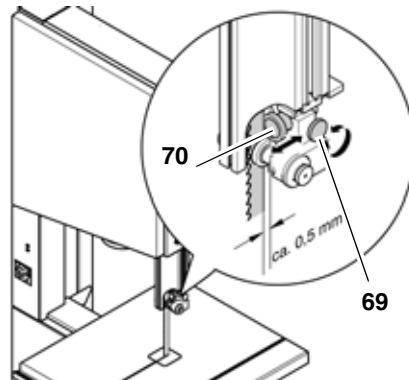

3. Adjust thrust bearing position (distance thrust bearing - band saw blade = 0.5 mm – if the band saw blade is turned by hand, it must not touch the thrust bearing).
4. Tighten the thrust bearing lock screw.

Adjusting the guide bearings

1. Loosen knurled nut (72).
2. Set guide bearings (73) with the knurled thumb screws (71) against the band saw blade.

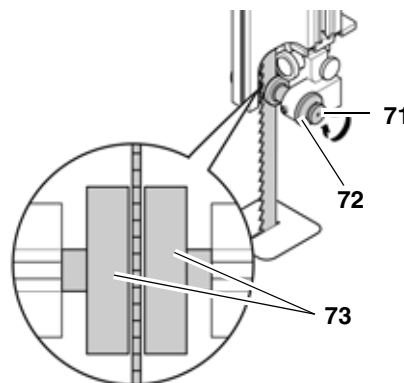

3. Turn band saw wheel by hand in a clockwise direction several times to bring the guide bearings in correct position – both guide bearings should just touch the band saw blade.
4. Retighten knurled nut (72) to lock the knurled thumb screw (71).

8.3 Aligning the Lower Blade Guide

The lower blade guide consists of:

- a thrust bearing (supports the band saw blade from the rear),
- two guide bearings (providing lateral support).

These parts need to be readjusted after every band saw blade change or tracking adjustment:



Note:

Periodically check thrust bearings and guide bearings for wear, if necessary replace both guide bearings at the same time.

Basic alignment

1. Open the lower housing door.
2. Slide hand guard into lower position and open lower blade guard (74).
3. Loosen the screw (75) for the lower blade guide.
4. Adjust position of lower blade guide until band saw blade is centred between the guide bearings (76).
5. Tighten screw (75).

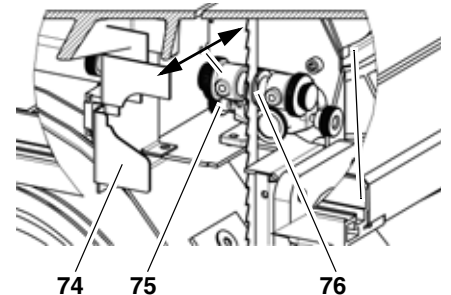

Adjusting the thrust bearing

1. Loosen the thrust bearing's lock screw (80).
2. Adjust thrust bearing position (81) (distance thrust bearing - band saw blade = 0.5 mm – if the band saw blade is turned by hand, it shall not touch the thrust bearing).
3. Tighten the thrust bearing lock screw (80).

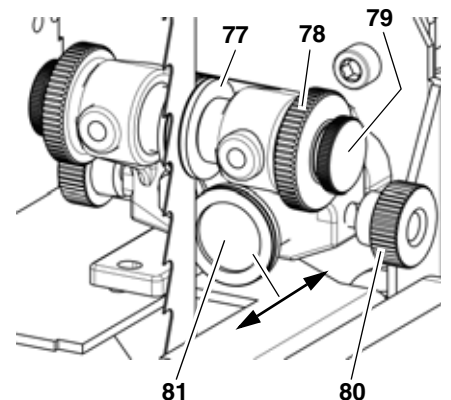

Adjusting the guide bearings

1. Loosen the knurled nut (78).

2. Set guide bearings (77) with the knurled thumb screws (79) against the band saw blade.
3. Turn band saw wheel by hand clockwise a few times to ensure that the guide bearings are in correct position – both guide bearings should be **lightly** touching the band saw blade.
4. Retighten knurled nut (78) to lock the knurled thumb screw .
5. Close lower blade guard (74)
6. Close the lower housing door.

8.4 Replacing the Band Saw Tyre

Periodically check band saw tyres for wear. Replace only in pairs:

1. Remove band saw blade (see “Care and maintenance”);
2. Lift band saw tyre with a small screwdriver, then pull off the band saw wheel.

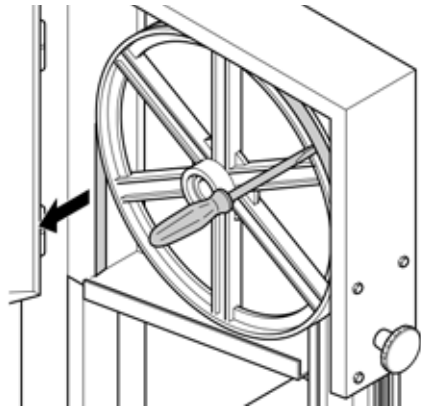

3. Mount new band saw tyres and re-install the band saw blade.

8.5 Replacing the Table Insert

The table insert needs replacement when its slot has become enlarged or damaged.

1. Remove table insert (82) from saw table (push up from underneath).

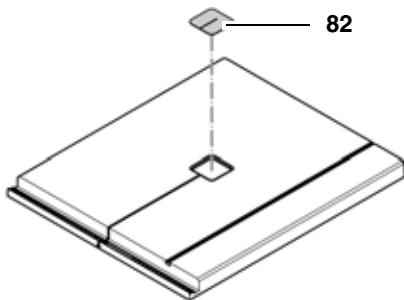

2. Fit new table insert.

8.6 Saw Cleaning



Danger!

Never touch the band saw blade or the band saw wheel with a brush held

in your hand when the saw is in operation!

Prior to all servicing:

1. **Switch machine OFF.**
2. **Wait for saw blade to stop**
3. **Unplug power cable.**

Saw Cleaning

1. Open housing door.
2. Remove chips and saw dust with brush or vacuum cleaner.
3. Close housing door.

8.7 Saw storage



Danger!

Store saw so that

- **it cannot be started by unauthorised persons and**
- **nobody can get hurt.**



Caution!

Do not store saw unprotected outdoors or in damp environment.



Caution!

Fold bandsaw blades when not in use and store dry.

9. Tips and Tricks

- Keep surfaces of the saw table clean – in particular, remove resin residue with a suitable cleaning and maintenance spray (optional accessory).
- Afterwards, apply a light coat of sliding compound (e.g. Waxilit).

10. Available Accessories

For special tasks the following accessories are available at your specialised dealer – see back cover for illustrations:

- A** Circle Cutting Attachment
For cutting circles of 120 to 260 mm diameter. Optimal cutting results when using a band saw blade for contoured cutting and radii.
- B** Wheel Set
For easy transport.
- C** Rip Fence
For making accurate long cuts.
- D** Mitre Fence Steplessly adjustable mitre angle from 90 ° to 45°.
- E** Precision Roller Guide
Provides optimal band saw blade guiding and prolonged service life.
- F** Belt Sanding Attachment
For finishing cut edges.
- G** Dust collection adapter for Ø 100 mm port.

- H** Dust collector
helps to protect your health and to keep the shop clean.
- I** WAXILIT Sliding Compound
Improves workpiece sliding on the saw table.
- J** Care and Maintenance Spray
For removing resin residue and preserving metal surfaces.
- K** Sanding Belt
80 grit, 3380 x 25 (pack of 3)
- L** Sanding Belt
120 grit, 3380 x 25 (pack of 3)
- M** Band Saw Blade A6
For cutting NF-metals
- N** Band Saw Blade A4
For contour cutting and small radii.
- O** Band Saw Blade A6
For cutting wood, straight cuts.
- P** Band Saw Blade A6
For cutting wood, universal cuts.
- Q** Band Saw Blade A8
For cutting firewood.

11. Repairs



Danger!

Repairs to electric tools must only be carried out by qualified electricians!

Electric tools in need of repair can be sent to the Service Centre of your country. Refer to the spare parts list for the address.

Please attach a description of the fault to the electric tool.

12. Environmental Protection

The machine's packing can be 100% recycled.

Worn out power tools and accessories contain considerable amounts of valuable raw and rubber materials, which are recyclable.

These instructions are printed on paper produced with elemental chlorine-free bleaching process.

13. Trouble shooting



Danger!

Before carrying out any fault servicing, always do the following:

1. **switch machine OFF;**
2. **Unplug mains cable.**
3. **Wait until the band saw blade has come to a complete stop.**

Check to see that all safety devices are operational after each fault service.

Motor does not run

Undervoltage relay tripped by power failure:

- switch on again.

No mains voltage

- check cable, plug, outlet and mains fuse.

Band saw blade wanders off the line of cut or runs off the band saw wheels

Band saw blade is not running properly on the band saw wheels:

- Correct tracking (see “Care and Maintenance”).

Band saw blade breaks

Incorrect tension:

- correct band saw blade tension (see “Care and Maintenance”).

Load too high:

- reduce pressure against band saw blade (reduced feed rate).

Incorrect band saw blade:

- replace band saw blade (see “Care and Maintenance”):

Contour cuts =
narrow band saw blade,

Straight cuts =
wide band saw blade.

Band saw blade warped

Load too high:

- avoid lateral pressure on the band saw blade.

Saw vibrates

Insufficient mounting:

- Fasten saw properly to a suitable floor (see “Initial Operation”).

Saw table loose:

- Align and fasten saw table.

Motor mount loose:

- Check fastening screws, tighten if necessary.

Dust extraction port blocked

No dust collector connected or suction capacity insufficient:

- Connect a dust collector or increase suction capacity (air speed ≥ 20 m/sec at dust extraction port).

14. Technical specifications

		WNB	DNB
Voltage	V	230 (1~ 50 Hz)	400 (3~ 50 Hz)
Nominal current	A	6,7	3,9
Fuse protection	A	10 (time-lag or K-Auto-mat)	10 (time-lag or K-Auto-mat)
Protection rating		IP 54	IP 54
Protection class		I	I
Performance			
Power input P1	kW	1.50 kW S6 40%	1.90 kW S6 40%
effective shaft output P2	kW	1.10 kW S6 40%	1.50 kW S6 40%
Rated no-load speed	min ⁻¹	1400	1400
Cutting speed	m/min	408/965	408/965
Band saw blade length	mm	3380	3380
Max. throat capacity	mm	440	440
Max. capacity under guide	mm	280	280
Max. band saw blade width	mm	25	25
Max. band saw blade thickness	mm	0,65	0,65
Dimensions			
Machine in packing			
– Length	mm	790	790
– Width	mm	710	710
– Height	mm	1970	1970
Machine ready for work (saw table horizontal)			
– Length	mm	834	834
– Width	mm	639	639
– Height	mm	1860	1860
Saw table only			
– Length	mm	640	640
– Width	mm	536	536
Weight			
Machine ready for work (with accessories supplied)	kg	133	133
Permissible ambient temperature for operation	° C	0 to +40	0 to +40
Permissible temperature for transport and storage	° C	0 to +40	0 to +40
Noise emission value (DIN EN 1870-1*) at idle			
A-sound pressure level L_{pA}	dB (A)	75,0	75,0
A-sound power level L_{WA}	dB (A)	84,6	84,6
Uncertainty K	dB (A)	4,0	4,0

		WNB	DNB
Noise emission value (DIN EN 1870-1*) during sawing			
A-sound pressure level L_{pA}	dB (A)	82,2	82,2
A-sound power level L_{WA}	dB (A)	89,9	89,9
Uncertainty K	dB (A)	4,0	4,0

* The values stated are emission values and as such do not necessarily constitute values which are safe for the workplace. Although there is a correlation between emission levels and environmental impact levels, whether further precautions are necessary cannot be derived from this. Factors influencing the actually present environmental impact level in the workplace include the characteristics of the work area and other noise sources, i.e. the number of machines and other neighbouring work processes. Also, permissible workplace values may vary from country to country. This information is intended to assist the user in his estimate of hazards and risks.

14.1 Available Band Saw Blades

Application	Dimensions mm	Tooth spacing	Stock number
NF-metals	3380 x15 x 0.5	A2	090 902 9210
Contour cutting	3380 x 6.0 x 0.5	A4	090 902 9180
Wood – straight cuts	3380 x 25 x 0.5	A6	090 900 0416
Wood – universal cuts	3380 x 15 x 0.5	A6	090 902 9171
Firewood	3380 x 25 x 0.5	A8	090 900 0424

metabo[®]

Metabowerke GmbH,
72622 Nürtingen, Germany
www.metabo.com

